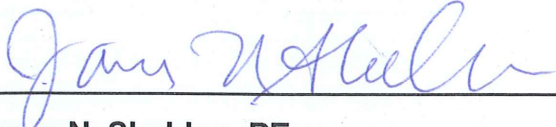

Design Criteria for Developer Connection to the New York Power Authority Transmission System

Rev. 1	 <hr/> James N. Sheldon, PE Director – Electrical Engineering Power Supply	03/03/2011
--------	--	------------

Revisions

Revision	Date	Description	Author
0	2/2/10	Original Issue.	JNS
1	3/3/11	Section 1.1 – Developer defined; Document availability defined; Document review and update schedule defined; A statement regarding document retention was added. Section 2.3 – The term Facilities was made specific to Generator Facilities.	JNS

DESIGN CRITERIA FOR DEVELOPER CONNECTION TO THE NEW YORK POWER AUTHORITY TRANSMISSION SYSTEM

CONTENTS

1.0	INTRODUCTION	4
1.1	Intent.....	4
1.2	Objective.....	5
2.0	SYSTEM REQUIREMENTS	6
2.1	Impact Studies	6
2.2	Connection Configuration	6
2.3	Connection Characteristics.....	8
2.4	System Operations	9
3.0	SYSTEM DESIGN CHARACTERISTICS	11
3.1	Electrical System Service Conditions.....	11
3.2	Lightning and Switching Overvoltage Protection.....	12
3.3	Insulation Coordination	12
3.4	Relaying Protection.....	12
3.5	Short Circuit Current	15
3.6	Protective Relay Settings.....	15
3.7	Metering.....	16
3.8	Communication Systems and Equipment	16
3.9	SCADA and RTU	18
3.10	Grounding	21
4.0	ENGINEERING AND DESIGN DOCUMENTS	24
4.1	Drawings.....	25
4.2	Specifications.....	28
4.3	Record Drawings	29
4.4	Turn Over Packages	31
5.0	EQUIPMENT AND MATERIALS	33
5.1	Power Circuit Breakers	33
5.2	Disconnect Switches.....	33
5.3	Potential Transformers.....	34
5.4	Current Transformers.....	34
5.5	Surge Arresters.....	34
5.6	Power Transformers	35
5.7	Control Building	35
5.8	Power Cables	38
5.9	Control and Instrumentation Cables	39
5.10	Cable Trenches, Conduits, and Trays.....	39

5.11	Lighting	41
5.12	AC Station Service Power.....	43
5.13	DC Station Service Power	44
5.14	Emergency Power	45
5.15	Bus and Bus Support.....	45
5.16	Insulators	46
5.17	Corona Control	47
5.18	Surge Counters.....	47
5.19	Acoustics	47
5.20	Electrical Identification	47
6.0	CIVIL, STRUCTURAL, AND MECHANICAL.....	49
6.1	Soil Conditions.....	49
6.2	Limits of Construction	49
6.3	Erosion Control	49
6.4	Drainage	49
6.5	Site Surfacing	50
6.6	Switchyard Structure Design.....	50
6.7	Foundation Design.....	52
6.8	Seismic Design	53
6.9	HV Circuit Breaker Platforms	54
6.10	Mechanical.....	54
7.0	ENVIRONMENTAL AND FLOOD HAZARD	56
8.0	SECURITY	58
9.0	FIRE PROTECTION, EQUIPMENT, AND PERSONNEL SAFETY ...	59
10.0	REGULATIONS, STANDARDS, AND CODES.....	61
11.0	APPENDIX	63
11.1	Appendix A - STL – FDR PROJECT DRAWING INDEX.....	63

1.0 INTRODUCTION

1.1 Intent

The Design Criteria For Developer Connection to the New York Power Authority Transmission System (DCDC) is a guide for Developers interconnecting to the New York Power Authority (NYPA) transmission system. A Developer is defined as any interconnecting entity. The DCDC document is available on the NYPA public website for public viewing/download (<http://www.nypa.gov/transmission/default.htm>). The DCDC will be reviewed and updated on an annual basis by the NYPA Electrical Engineering group. Previous versions of this document will be retained in accordance with NYPA's documentation retention policy.

No guideline can anticipate all the specific requirements for a project to be designed and constructed in the future. Requirements change as regulatory agencies update rules or regulations, or as NYPA practice changes. Developer shall consider requirements in the DCDC to be the minimum requirements. In addition, Developer shall use project specific interaction with NYPA including correspondence, email, meetings / meeting notes, and Requests for Information / responses to prepare the project specific design for submittal NYPA. The approved design will govern.

The NYPA system is divided into three major regions: Niagara (NIA), St. Lawrence (STL), and South East New York (SENY). Requirements specific to each region will have differences to some requirements in the DCDC; these shall be incorporated by Developer during detail design.

The Developer shall provide a complete integrated, coordinated design, construction, quality assurance, and documentation process. The design shall consist of coordinated specifications, calculations, drawings, etc. The intent is that when the project is complete the Developer will have provided a facility that meets contractual, regulatory, and NYPA requirements, plus complete Record Drawing and Turn Over Package documentation that NYPA will use to operate and maintain the facility to regulatory requirements and NYPA standards and practice.

NYPA criteria include safety during Construction and Operations, Reliability, Maintainability, Good Utility Practice, and compatibility with NYPA's Clearance and Protection Procedure (CPP-1).

NYPA Project and Construction Management requirements are provided in the Project Management Criteria For Developer Connection to the NYPA Transmission System document (PMC). Developer shall use the PMC in conjunction with this DCDC document.

In this document the word "shall" means that provisions are mandatory. The word "should" indicates provisions that are generally practical. For exceptions to "shall" or "should" provisions, Developer shall submit specific requests including proposed/recommended

resolution and explanation, and obtain NYPA approval prior to proceeding. “Or equal” or “or equivalent” means “or NYPA approved equal/equivalent”; “approved” means “NYPA approved”; “including” means “including, but not limited to”. “Switchyard” is used to identify the substation or switchyard which Developer shall provide for NYPA ownership that NYPA will operate subsequent to construction and turnover.

Developer will construct a switchyard for a new connection to the transmission system. Alternately the Developer will construct facilities in an existing NYPA substation. The Developer’s substation containing generation step-up transformer(s) shall be external to the NYPA switchyard.

References in this document to items to be submitted shall be submitted by Developer to NYPA for NYPA review and approval. NYPA review, comments or approval shall not be construed as confirming, endorsing, or providing a warranty as to the design, fitness, safety, durability or reliability. Developer shall make such changes as may reasonably be required by NYPA, in accordance with Good Utility Practice, to ensure that the facility is compatible with the technical specifications, operational control, and safety requirements of NYPA. NYPA shall not, by reason of such review or failure to review, be responsible for compliance with codes and/or standards. These responsibilities shall remain the Developer’s obligation.

Items or requirements in this DCDC document do not diminish or supersede requirements of Codes, Standards, New York State Building Code (NYSBC), the Interconnect Agreement (IA) or Developer’s obligations. As Developer encounters conflicts or requires clarification, Developer shall submit to NYPA for resolution. Developer shall coordinate requirements and resolve issues.

1.2 Objective

This document includes the design criteria/ minimum requirements for the design and installation of equipment to be connected to the NYPA transmission system at the 115 kV, 230 kV or 345 kV voltage levels. Developer shall coordinate, plan, design, construct, and test interconnection facilities in compliance with criteria set forth by the NYSBC, New York Independent System Operator (NYISO), New York State Reliability Council (NYSRC), Northeast Power Coordinating Council (NPCC), North American Electric Reliability Corporation (NERC), the Federal Energy Regulatory Commission (FERC), NYPA, and other agencies with jurisdiction.

Approval of the connection concept will be evaluated against statutory, contractual, regulatory, and tariff requirements. The connection configuration shall not result in adverse effects on the NYPA transmission system, NYPA customers’ equipment or the general public, or adversely impact NYPA’s existing contractual rights or obligations.

The design, equipment, installation, and testing shall comply with codes, standards, Good Utility Practice, IA, and NYPA requirements. Developer shall submit the design including equipment and design specifications, drawings, and calculations.

2.0 SYSTEM REQUIREMENTS

2.1 Impact Studies

All connections to the NYPA transmission system must follow the NYISO Interconnection Process defined in the NYISO Open Access Transmission Tariff (OATT). This process includes filing an Interconnection Request and performing a Feasibility Study, System Reliability Impact Study, and Facilities Study.

2.2 Connection Configuration

The connection configuration shall be submitted.

Connections of facilities to the NYPA transmission system, into a switchyard or a transmission line, shall be in an acceptable configuration:

- The Switchyard connection shall be terminated into an existing switch position as shown in Figure 1. Each connection requires two associated circuit breakers to permit operation with one circuit breaker out of service. Thus a new connection might be terminated into a new switchyard bay with two new circuit breakers CB1 and CB2 (Figure 1a) or into an expanded existing bay with one additional circuit breaker CB2 or CB3 (Figure 1b).

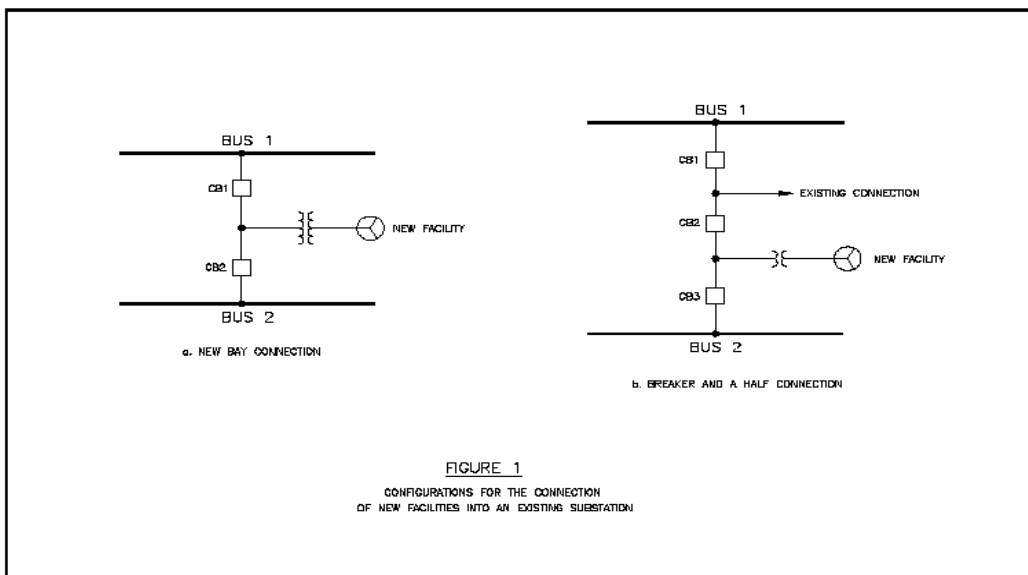

- Connections to a transmission line shall be terminated in a switchyard. The switchyard for a single Developer connection shall be a ring bus configuration. For example with a three-breaker ring bus configuration, two ends of a segmented transmission line will be connected through circuit breaker CB1 and the facility connected through two circuit breakers, CB2, and CB3 (Figure 2a). In some cases, addition of a fourth circuit breaker in series with CB1 may be required.

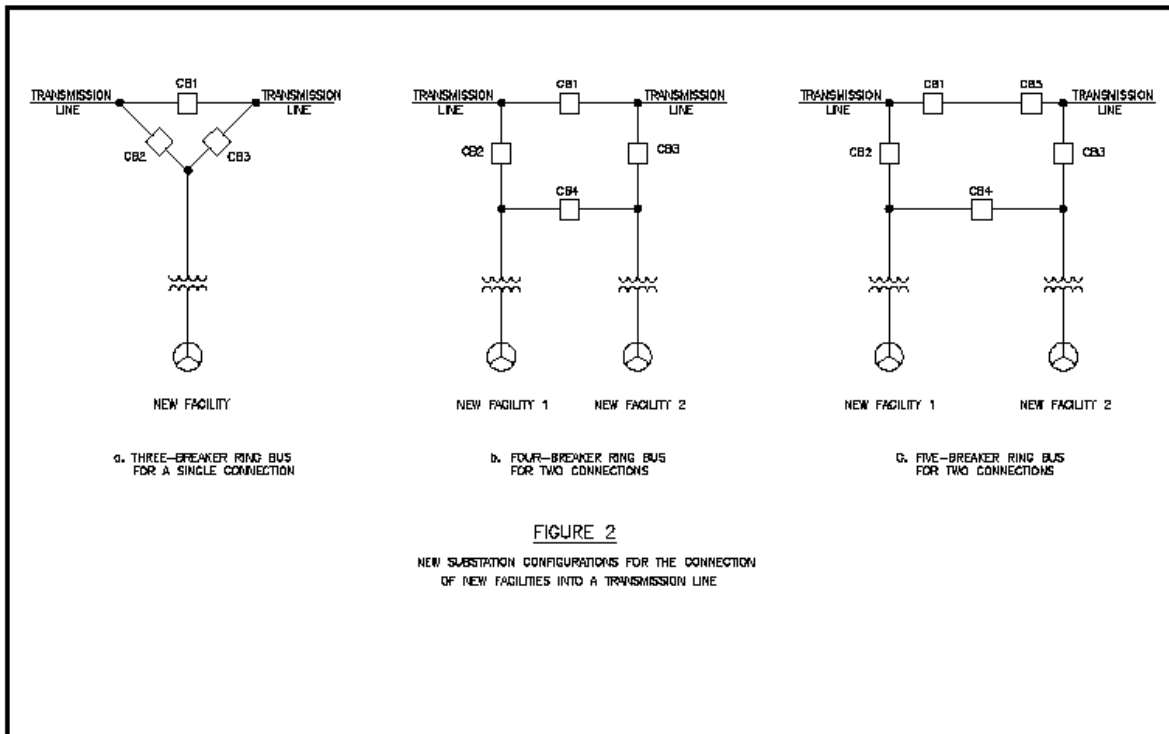

- For a switchyard with two Developer connections the circuit breaker configuration may be a four breaker ring bus (Figure 2b), similar to the previous case. In such a configuration the line terminals are connected at the switchyard through CB1 while the facilities are connected to the ring bus by CB2 and CB4 (Facility 1) and by CB3 and CB4 (Facility 2). In a four-breaker ring bus configuration with two connecting facilities, only failure of CB1 (Figure 2b) results in the shutdown of the transmission line and isolation of the connected facilities. Failure of any other circuit breaker in this configuration leads to the opening of two adjacent circuit breakers and keeps one of the facilities connected to a transmission line terminal. The complete isolation of the facilities during CB1 failure in a four-breaker ring bus can be avoided by installing an additional circuit breaker in series with CB1 (Figure 2c).

The minimum switchyard configuration is a three breaker ring bus in a two bay configuration. Developer's submitted configuration shall be reviewed by NYPA and

affected transmission owners during the NYISO Interconnection Process and IA negotiation.

2.3 Connection Characteristics

Generation facilities shall interface with the NYPA system by means of a transformer or bank of transformers. The facilities shall not cause reduction in the quality of service provided to NYPA customers. Voltage limits for generators connected to NYPA transmission facilities will be determined by NYISO/NYPA.

Relaying equipment shall provide automatic separation of the facility from the NYPA system. Each connection shall be provided with switching and control devices capable of interrupting system short circuit currents at the connection location. The facility shall be equipped with a visual separation from the NYPA system.

A SCADA Remote Terminal Unit (RTU) shall be provided. The RTU shall be compatible with the NYPA Control System. The RTU will provide System Operations personnel control and status monitoring of the circuit breakers, disconnects, MODs, etc. The RTU shall also have the capability of transmitting analog quantities.

Reactive compensating devices shall not be installed without approval of NYPA / NYISO.

A generating plant shall be able to:

1. Operate continuously within voltage variations of +/-10% for 115 kV system and -10% /+5% for 230 kV and 345 kV systems.
2. Withstand system voltage disturbances in accordance with the time periods and associated voltage levels summarized in Figure 3 (FERC Order 661).
3. Operate within +/-0.95 power factor at the point of connection to the system.
4. Comply with IEEE 519 "Recommended Practices Requirements for Harmonic Control in Electrical Power Systems".

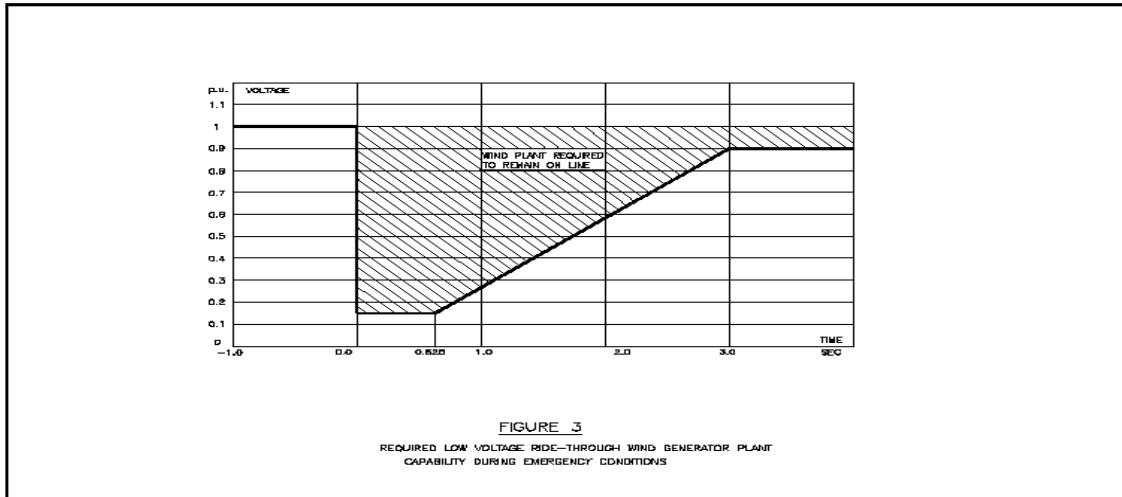

2.4 System Operations

Operating guidelines shall be defined in the Operations Coordination Agreement.

NYISO, in coordination with NYPA, reserves the right to open switching devices without prior notice to Developer for any of the following reasons:

- System emergency or system conditions leading to a possible system emergency.
- Inspection of the connecting facilities or protective equipment reveals a hazardous condition.
- The connecting generating equipment or power transaction interferes with NYPA customers or with operations of the NYISO system.
- Failure to maintain the connecting facilities in accordance with the IA.

Connection equipment between the facility generators and the point of interconnection with the NYPA system shall be inspected and approved for service by NYPA prior to energization.

The Developer is responsible for generator synchronization to the transmission system. The limits established by NYISO for frequency and voltage shall be observed when connecting or disconnecting the generators or station loads from the system.

The Developer shall not be permitted to energize or de-energize NYPA circuits. Energization of the Developer's facility shall be coordinated with NYPA operations. The Developer shall schedule facility outages with NYPA. The Developer's facility shall have controls which are compatible with the controls of the NYPA control area. If Developer's generators remain connected to a de-energized line, Developer's controls shall automatically open the breakers connecting to NYPA's system so that the NYPA switchyard breaker(s) can be reclosed and the circuit reconnected to the supply bus.

Emergency generator(s) connected to the Developer's system shall not operate in parallel with the NYPA system. Developer's facilities shall not create an energized feedback condition when the NYPA system is de-energized. Electric systems with emergency generators connected must be provided with a break before make transfer switch or other approved method to prevent emergency generator operation in parallel to the NYPA system.

3.0 SYSTEM DESIGN CHARACTERISTICS

3.1 Electrical System Service Conditions

Main system parameters, meteorological conditions and clearances at the switchyards are summarized in Tables 3.1.1 - 3.1.3.

3.1.1 Electrical System Parameters

Nominal Voltage, kV	115	230	345
Maximum Operating Voltage, U _{max} , kV	126	242	362
BIL, kV (Clean Insulators)	550	900	1050
BIL, kV (Contaminated Insulators)	550	1050	1300

Transmission system continuous current and short circuit current ratings are site specific. These ratings will be specified by NYPA.

3.1.2 Meteorological Conditions

Ambient Temperature Range	-40°C to +40°C
Average Ambient Temperature	30°C
Max Bus Temperature Rise	50°C
Altitude	<1000 m
Max Gust Velocity	90 mph
Max Sustained Wind Velocity	15 mph
Wind Velocity	2 fps
Keraunic Level	per Keraunic Chart

3.1.3 Minimum Switchyard Clearance Distances

The clearance distances for switchyards are presented as a function of outdoor insulation BIL. For 230kV switchyards 900kV or 1050kV BIL shall be provided; for 345 kV switchyards 1050kV or 1300kV BIL levels shall be provided, see Section 3.3 B.

BIL, kV	550	900	1050	1300
Metal-to-Metal for Rigid Conductors	4'-5"	7'-5"	8'-9"	9'-11"
Center Line-to-Center Line for Rigid Buses	7'-0"	11'-0"	13'-0"	15'-0"
Rigid Conductor-to-Grounded Parts	3'-6"	5'-11"	6'-11"	8'-8"
Bare Overhead Conductor-to-Ground	12'-0"	15'-0"	16'-0"	18'-0"
Bare Overhead-to-Roadway	30'	34'	34'	37'
Rigid Bus-to-Roadway	22'	24'	24'	26'

3.2 Lightning and Switching Overvoltage Protection

- A. Lightning protection shall be accomplished by lightning masts and shields installed within the territory of the switchyard. The probability of protection shall be 99%. The lightning masts and shields shall be directly connected to the switchyard ground via minimum 4/0 soft drawn annealed copper conductor.
- B. All equipment installed in the switchyard shall be protected from lightning and switching overvoltage by surge arresters whose rating is determined by insulation coordination studies.

3.3 Insulation Coordination

- A. Early in design development Developer shall submit insulation coordination studies including site specific BIL recommendation. Consider stresses due to lightning, switching surges, and other transient phenomena which may cause overvoltage.
- B. For systems operating at 230kV and above, two BIL levels are available for each voltage. In each case the lower BIL level is acceptable for clean environment sites, while the higher BIL level shall be provided at locations where there is significant potential of insulation contamination.

3.4 Relaying Protection

- A. The Developer shall submit Relaying and Metering single line drawings including step-up transformers and connections to the NYPA system. The drawings shall include major components with specifications and ratings, protective relaying, and instrument transformers with their full and applied tap ratio information used for each protection zone element. Discrete and multi-function protective relays shall be depicted with each activated function and associated input sources and output trip device designations.
- B. The protective relaying system shall be designed to coordinate with other segments of the transmission system based on analysis of system faults and transient stability of the system for various system conditions to attain the required speed of interruption.
- C. The relay protection system shall be engineered in accordance with NYPA design standards. Detailed specifications for the interconnection relay protection shall be provided in the project specific NYPA General Design and Application Guides. The protection systems illustrated on the

functional relaying diagram shall include all elements of:

- Transmission line protection
- Transformer and reactor protection
- Bus protection
- Breaker failure protection
- Independent primary and secondary systems from diverse manufacturers for each of the above
- Generator protection
- Station service transformer protection
- Synchronizing and synch check relaying
- Distribution line protection
- Miscellaneous service protection
- Special Protection Systems or Remedial Action Schemes
- Reclosing
- Stub-bus Protection
- Circuit Breaker Low Gas Pressure Protection

D. The diagrams shall include:

- Point of Interconnection to NYPA system
- Switchyard equipment and ratings
- Relay manufacturers
- Relay models with ANSI device numbers
- Relaying schemes
- Zones of protection
- Associated instrument transformer ratios and accuracy class
- Auxiliary relays and relay communication equipment

E. If the facility is to be connected to a NYPA facility considered part of the Bulk Power System (BPS), the interconnecting facility's protection system shall comply with Northeast Power Coordinating Council (NPCC) Bulk Power System Protection Criteria and NERC Reliability Standards.

F. Developer shall design and document the protection systems for all equipment. The protective relay and design for the line, bus, transformer, breaker, and other switchyard equipment for the interconnecting facility shall be submitted for review by NYPA Protection & Control Engineering (PCE) group.

- G. Each step-up transformer connected to the NYPA system shall have delta winding configuration on the high-voltage (NYPA connected) side of the transformer.
- H. All protective relay systems shall be fully numerical, microprocessor-based relays with GPS clock time stamped fault data recovery via sequence of events, waveform capture, and relay watchdog functions.
- I. When the interconnection is to the BPS, or if the interconnection is to a critical NYPA circuit, each HV circuit breaker shall be provided with two completely separate breaker failure relaying systems.
- J. Depending on the classification of the particular line system configuration and/or conditions, special protection or additional redundant systems may be required.
- K. Instrument transformers used for protective relaying shall be of C800 accuracy class. HV circuit breakers shall have dual independent trip coils.
- L. The relay cabinet and the panel layouts shall be submitted. Specification for relay panel design will be provided by NYPA in the standard EDS-PCE110 "Electrical Design Standard for Indoor Protective Relay Panel/Cabinets and Terminal Cabinets". Developer shall provide space and layout for future addition of relay control panel cabinets in each of the primary room (minimum 4 cabinets) and secondary room (minimum 6 cabinets).
- M. The DC power supply for the protective relaying and communication system shall be 125 VDC battery sources in accordance with the DC station service section of this document. Fully redundant battery systems and chargers shall be provided for BPS interconnections and interconnections to systems designated critical by NYPA. Relaying and annunciation for the 'loss of DC' to protection and breaker control circuits shall be provided locally and remotely.
- N. Automatic re-closing requirements shall be determined by NYPA based on the location of the interconnecting facility.
- O. Automatic synchronizing and manual synchronizing including Synch Scope shall be provided.
- P. Interlocks and/or synch check equipment shall be provided to allow the remote operation of the switchyard breakers.
- Q. Stand alone Sequence of Event Recorder equipment and Digital Fault Recorder equipment shall be provided per NYPA specifications.

Developer shall provide engineering drawings documenting the design, installation, and functional testing (yellow line).

- R. A HMI (Human-Machine Interface) computer including software shall be provided for local status indication, metering, and alarm annunciation / acknowledgement. The HMI shall be capable of providing status indication, metering, and alarms via interface with the SCADA RTU. The HMI shall be powered from a non-interruptible power source.
- S. All HV circuit breakers and motorized disconnect switches shall be provided with local and remote control and status indication. Manual disconnects shall be provided with local and remote position indication.
- T. Relay equipment status, trouble and failure alarms shall be wired to the SCADA RTU for remote monitoring.
- U. Local control and panel devices (switches, lights, synch scope, etc.) shall be provided.
- V. Phase angle transducers shall be provided to measure the phase angle across HV circuit breakers. They shall be connected to the SCADA RTU for monitoring.
- W. Breaker control and relay protection circuits shall be configured with relay and breaker control functions segregated and separately fused. This usually relates to the protection relays that would in some designs be powered by the breaker control fuses in schemes including synch check or reclosing. Developer shall coordinate this design aspect with NYPA.

3.5 Short Circuit Current

NYPA shall provide the site specific available short circuit current design criteria along with the system X/R ratio. The Developer shall submit short circuit studies with variations and contingencies of fault currents for proper coordination and settings of protective relay system and for the selection of switching equipment.

3.6 Protective Relay Settings

Developer shall submit relay setting calculations, justifications, and applied settings for the switchyard and Developer's switchyard protective relaying. Developer shall submit preliminary relay setting calculations including the basis used for the calculations and the applied settings. Developer shall submit final commissioned in-service relay setting files in a complete report including the basis for calculations. These submissions shall be in editable Word (doc(x) file) format. The Developer shall apply settings for the

transmission line and feeder protective relaying up to and including the adjacent terminals and from POI to the Developer's switchyard or generator step up transformers.

3.7 Metering

Revenue metering shall be at the point of interconnection, e.g. the high-voltage side of the step-up transformer, and shall include the following:

- A. **Instrument Transformers:** The specific type, number, connection, and ratios of the instrument transformers will be determined by NYPA PCE/Metering groups based on the expected output and load and the connection to the NYPA system.
- B. **Intelligent Electronic Devices (IEDs):** The IEDs for revenue metering MWH, MW, and MVAR and other electrical indications will be supplied by NYPA and mounted in a separate metering cabinet. These devices will be connected to the RTU via RS232, RS485 or Ethernet connection. Ethernet and land line or cellular communications shall be provided by Developer for redundant communications paths to the IEDs as described in the SCADA RTU section.
- C. **Metering Cabinet:** The metering cabinet(s) shall be a free-standing or wall mount lockable, sealable cabinet located near the SCADA RTU cabinet. AC and DC station power shall be supplied to the metering cabinet(s).
- D. **Instrument Transformer Secondary Wiring:** PT and CT secondary wiring shall be routed underground in a dedicated PT conduit and a dedicated CT conduit ("home runs") from the instrument transformers to the meter cabinet. These CT and PT secondary wiring conduits shall not run in the yard common wiring trenches, shall be segregated from all other power cables, and shall be routed at a distance to eliminate the influence from other voltage and current carrying cables. Developer shall provide lockable / sealable CT/PT junction box at the base of the CT/PT structure for shorting and fusing. Additionally, a lockable / sealable Burden Limiting Fuse Box may be required on PT secondary connections. The CT/PT junction box and Burden Limiting Fuse Box will be supplied by NYPA. Only multi-conductor control cable may be utilized with a minimum 600V AC insulation level. Minimum # 10 AWG stranded copper cable shall be used for the CTs wiring and minimum #12 AWG stranded copper shall be used for the PTs wiring. Additional control cable requirements, such as shielding and twisted pairs, may be specified.

3.8 Communication Systems and Equipment

- A. Communication systems shall be provided to integrate seamlessly into the existing and planned NYPA communication systems. The systems shall provide

for inter-connectivity with the switchyard and the NYPA system. The system shall utilize mediums specified by NYPA. The system shall provide continuous communication from the facility to the designated NYPA termination location.

The systems shall have the capability to transmit and receive various types of signaling including metering, relay protection, security, CCTV, voice, life safety, alarms, and SCADA equipment.

Developer shall provide the switchyard audio public address system including indoors serving the NYPA Control Building and outdoors in the switchyard. Developer shall provide local and remote paging from any NYPA location.

- B. NYPA will provide Developer with communication systems high level specification including interconnectivity with existing and planned NYPA systems. The Developer shall design and provide the communications systems.
- C. Circuits designated by NYPA as critical shall be supported by two separate communication mediums / pathways. Any diverse transmission medium or other broadband based facilities supplied by common or value added carrier shall be configured dedicated point to point. Virtual circuits shall not be allowed.
- D. System security requirements using encryption or other means shall be specified by NYPA.
- E. Certain communications applications, e.g. SCADA, Protective Relaying, shall be provided via minimum two full DS1 Channels/ Ethernet pathways. Additional separate DS1 channels/bandwidth shall be supplied for the other applications, plus spare capacity.
- F. The communication system design shall include:
 - 1. The communication system and related equipment shall be provided with redundant power supplies and related equipment.
 - 2. If a standalone building supporting microwave equipment is provided, it shall be provided with a dedicated UPS system, redundant HVAC sources, stand alone battery bank, and space for future addition of equipment.
 - 3. NYPA will specify communication requirements and will apply for FCC license, FAA filings, etc. NYPA shall be the named licensee for Communications licenses and permits.
 - 4. The public address system shall have a minimum impact on surrounding areas and conform to Federal, State, and local ordinances and regulations. Submit supporting calculations.

5. Lightning protection shall be provided for communication equipment. Bonding and grounding shall conform to the latest edition of the Motorola R56 manual, "Motorola Standards and Guidelines for Communications Sites", and NFPA.
6. All telephone or T1 facilities including broadband entering a switchyard shall be via buried non-conductive fiber optic cable.
7. Developer shall supply a plain old telephone (POTS) circuit and phone handsets. In addition, a minimum of six telephone circuits shall be integrated into the NYPA region phone system:
 - Ring down line to control center (multiple extension locations)
 - Gate phone (plus provide key or card key access at truck and automobile window heights)
 - Primary room (multiple extension locations)
 - Secondary room (multiple extension locations)
 - Public address
 - Breaker cabinet circuit (bridged, jack located in each HV Circuit Breaker cabinet)

Handsets for POTS and NYPA circuits shall be provided at multiple locations (in addition to that of the corresponding designation); submit layout. Developer shall provide telephone handsets with audible ring and visual flashing light indication.

8. Developer shall install local area network (LAN) jacks at primary, secondary, control room desks, and other locations; submit layout.
9. Communication equipment shall be installed per industry standards and NYPA practice.
10. Communication facilities shall be designed assuming they are Critical Assets. The installation shall comply with NERC-CIP, see below section.

3.9 SCADA and RTU

- A. Developer shall provide a SCADA RTU (Supervisory Control and Data Acquisition Remote Terminal Unit) per NYPA specification in the switchyard Control Building. At NYPA option, NYPA will order the network routers, switches, and/or firewalls as appropriate for installation by Developer. Developer shall contract with the RTU manufacturer to configure the RTU.

- B. Developer shall notify NYPA and coordinate so NYPA personnel may observe RTU manufacturer's work.
- C. The minimum SCADA RTU communication channel is a dedicated, non-virtual, T1.5 digital point-to-point circuit from the facility to NYPA's existing control center.
- D. Developer shall install the network routers, switches, and firewalls in a separate free-standing, lockable cabinet provided with tamper switches wired to the RTU. Equipment (routers, switches, etc.) for SCADA communications shall be powered by station batteries via redundant power supplies, see figure below. Equipment servicing diverse communications pathways shall be powered by separate station batteries.

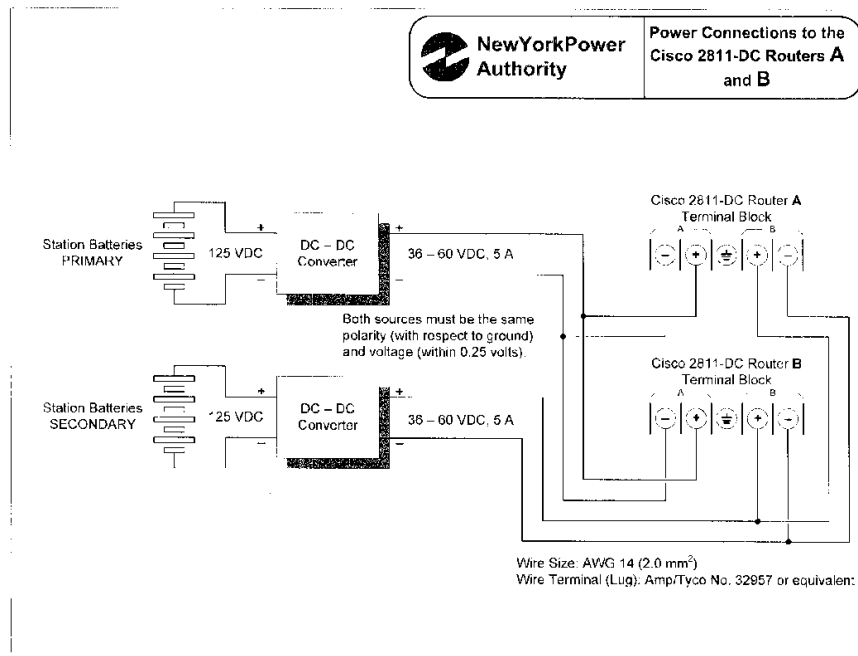

- E. Each Router/Switch shall communicate using a standard T1.5 digital termination facility. In the configuration typical, two (2) T1.5 digital facilities shall be supplied by the Developer. The intent is to provide true diversity for the switchyard communication system. Typically the first T1.5 digital facility shall be supplied via a microwave system. The diverse T1.5 digital facility will be the point-to-point common carrier supplied pathway. The two T1.5 digital facilities may not share the same physical or electrical paths. A typical configuration is shown below.

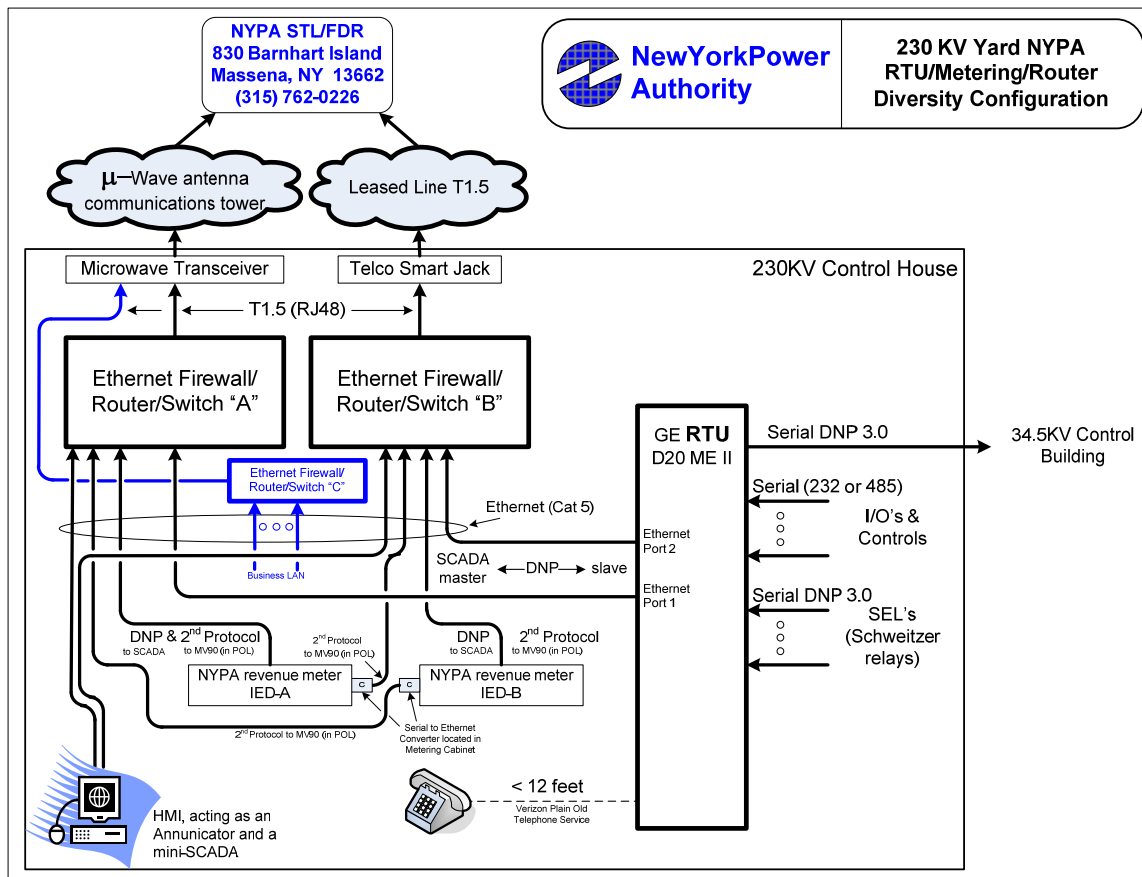

- F. Hardwired equipment status inputs shall utilize dry contacts only. Hardwired analog inputs shall utilize ungrounded current (+/- 1mA inputs (nominal) or 4-20mA transducer inputs). The RTU shall also be capable to poll intelligent electronic devices (IEDs) using DNP 3 and MODBUS RTU protocols via serial or Ethernet connections. Connections between the RTU and protective relaying shall be hardwired. Serial connections that extend outside the Control Building shall connect to the RTU via Fiber/RS232 converters. Ethernet connections shall utilize switchyard qualified Ethernet switches installed no more than 20 feet from the RTU.
- G. The RTU shall be enclosed in a free standing lockable cabinet provided with tamper switches wired to an RTU input, be installed in the Control Building, typically with front and rear access. Cabinets will provide for top and bottom cable entry compatible with the Control Building design. At minimum a POTS line handset and a NYPA extension handset shall be installed maximum of 12' from the RTU.
- H. Developer shall provide the HMI computer and software per NYPA specification.

- I. If the cyber facility is categorized by NYPA as part of the BPS, the RTU and communication cabinet shall be protected both physically and electronically to NERC CIP requirements, including:
 1. Card Key access control with logging of the access to the equipment.
 2. Video monitoring/Storage/Offsite Communication.
 3. Separate secure room (preferred) or “six” wall enclosure, such as a security cage, if the physical area around the device cannot be secured from general access.
 4. TCP/IP access should be limited, monitored, and controlled via firewalls, Intrusion Detection.
 5. Dial-up access is prohibited.

3.10 Grounding

- A. The switchyard grounding system shall be comprised of ground rods and ground grid. The grounding system shall be designed to provide safety for personnel, protect equipment, and property. The system shall be designed with sufficient fault current flow to ground for reliable operation of relaying protection.
- B. The perimeter of the ground grid shall be extended minimum 3’ outside the fence of the switchyard. For outward swinging gates, the ground grid shall be extended to encompass the total gate swing plus 3’.
- C. The grounding system shall encompass the switchyard yard, switchyard fence, and Control Building.
- D. The criteria for a safe, effective, and reliable grounding system shall be the value of ground grid resistance, the level of step and touch potential, and the magnitude of fault currents flowing to ground. Developer shall submit soil test data, design data, and calculations.
- E. The ground grid shall be buried minimum 2’ below grade, with a parallel and perpendicular pattern of grid conductors.
- F. A minimum of ten (10) soil resistivity tests shall be conducted. The average test value shall be used in calculations to determine the optimum configuration of the grounding grid and the depth and quantity of ground rods.
- G. The grounding system resistance prior to connection to the out of switchyard grounding system shall be less than 2 ohms. The Developer shall obtain the maximum system line to ground short circuit current design criteria from NYPA.

- H. A minimum of two test stations shall be constructed and covered with hand-holes on the top of the rods for maintenance access.
- I. The grounding system in the Control Building shall include a separate approach, which shall be bonded together with the yard grounding system to form one complex grounding system. The special grounding for the Control Building shall be a high frequency grounding system. The metallic enclosures and panels shall be connected to a reference ground to minimize high frequency noise. Equipment connection details shall be provided.
- K. Submit grounding design drawings including minimum of three separate layout drawings: for switchyard, fence grounding, and the Control Building. Provide equipment grounding details and grounding details.
- L. All structures and equipment shall be grounded to a common ground grid. Minimum #4/0 AWG bare stranded soft drawn annealed copper shall be used for the ground grid as well as for connections to equipment and structures. Exothermic connections shall be used for below grade connections. Above grade connections to equipment and structures shall be bolted or crimped.
- M. Transformers, cooling tanks, circuit breaker tanks, and support structures shall be grounded at two points at diametrically opposed corners. Other equipment shall be grounded at minimum one point. HV disconnect and ground switch operating handle location(s) shall be provided with an at-grade grounding mat. The grounding mats shall be connected to the grounding grid at two locations. Platforms for access due to the height of the cabinets (e.g. HV circuit breaker cabinets) shall be grounded at two opposed locations.
- P. All cable shields, except instrumentation cable shields, including those of the station service transformer feeders, shall be solidly grounded at both ends, unless otherwise specified by NYPA. Instrumentation cable shields shall be grounded at the cabinet end. Provide equipment grounding conductors. Metallic conduits, whether embedded or exposed, shall be electrically continuous and bonded at both ends. Flexible conduits shall be installed with bonding bushings and external bonding jumpers.
- Q. All outdoor equipment cabinets and junction boxes shall have a ground connection to the ground grid.
- R. The switchyard fence and gates shall be grounded. Every other steel post of the switchyard fence shall be grounded. The barbed wires shall be connected to ground at every other post using screw connectors and

minimum 2/0 AWG stranded soft drawn annealed copper wire to the ground connection at the base of each grounded post.

4.0 ENGINEERING AND DESIGN DOCUMENTS

Engineering Documents including drawings, specifications, calculations, studies, reports, etc. shall be signed and sealed by the Engineer of Record (EOR), a New York State (NYS) licensed Professional Engineer (PE), in accordance with NYS Education Department guidelines.

Design drawings, specifications, and Contractor submittals including catalog cuts, manufacturers' documentation, shop drawings, etc. shall be submitted. Submittals shall include calculations, assumptions, and supporting documentation. Submit studies and calculations including: time-over current protection, protection coordination, insulation coordination, AC and DC fuse coordination, and ground grid. Prior to submittal Developer /Contractor submittals shall be stamped to indicate approval by the EOR.

Calculation submittals shall be formatted to include: Summary of Results, Purpose, Basis, Assumptions, References, and Detailed Calculations.

Developer shall provide the design, drawings, calculations, and specifications complete and coordinated in detail. Developer shall provide complete detailed design packages in accordance with Good Utility Practice that will be used for Construction, Operations, Maintenance, and Clearances under NYPA's CPP-1 program. Design / Build quality drawings and specifications are not sufficient. The design packages shall include drawings, specifications, and calculations that unambiguously detail the design. The intent is that the construction contractors may construct the design with a minimum of field interpretation, and that the As-Built and record documents faithfully and unambiguously document the installation and testing, including down to the detailed point to point wiring level.

The design drawings and specifications shall be submitted in logical packages for each design phase including Schematic, For Design, For Construction. Developer shall submit As Built Drawings and Record Drawings. Developer's project schedule shall allow sufficient time intervals for NYPA review/approval, and for re-issue of drawings and specifications required thereby.

Developer shall submit, administer, and enforce a rigorous Design Quality Assurance / Quality Control (D-QA/QC) Program and proactively quality assure the design packages prior to submittal including "Yellow Lining" prior to drawing package submittal. Design submittal Yellow Lining includes the physical checking, marking, initialing, and dating of the drawings as part of the design check and coordination D-QA/QC process.

Developer shall also provide Construction Yellow Lining as part of the Record Drawing Process, see below.

Developer shall provide extensive labeling of items including: panels, panel schedules, equipment, conduits, cables, terminations, etc. Labels shall coordinate exactly to the drawings in order to comply with CPP-1 and to ensure the safety of personnel. Developer shall coordinate labels with NYPA including equipment, yard equipment, and structures. Developer shall coordinate with NYPA the cable and termination labeling. Developer shall coordinate with NYPA to incorporate any non-industry standard labels (e.g. DC label colors for 125V DC terminations). See also Section 5.20.

Developer shall maintain an organized Request for Information (RFI) process and database for RFIs.

Developer shall provide databases including Drawing Index / database, Specification Index / database, Calculation Index / database, Equipment Index / database, Bill of Material (BOM) / database, and Vendor Drawing Index / database. The Drawing Index database shall track drawings, drawing revisions, submittal dates / transmittal numbers, comments / responses / transmittals, etc.; similar for the Specification database. Each equipment item shall be assigned a unique equipment number. The BOM shall have unique designations for each material item that will be coordinated onto the drawings – each drawing BOM will not start with item number 1, rather items shall coordinate to the BOM database number. BOM item numbering shall not be fully consecutive. Rather BOM items should be grouped in logical system groups and sequences, with gaps in the numbering to allow BOM items to be added in the latter stages of design and construction.

Databases shall be MS Access or approved format. Databases shall be kept up to date contemporaneously with submittal transmittal.

Developer shall coordinate with NYPA to establish the Drawing Index and drawing numbers, and to detail the drawing and drafting requirements for the interconnection design. Developer shall coordinate requirements to NYPA standard Appendix F: Computer Aided Drawing Requirements For New York Power Authority. Developer shall supply NYPA standard ANSI “E” size drawings.

Developer shall submit and administer a detailed Change Control Program that ensures that changes made by the EOR are documented on the design documents and submitted, and that field changes have been approved in advance of installation by the EOR and NYPA. Developer Change Control Program shall conform to the NYPA Configuration Management policy.

4.1 Drawings

Developer drawings shall detail the Work. Changes to the content of a drawing shall result in the incrementing of the revision from A to B, B to C, etc. Addition and deletion changes shall be described in the revision block or by notes on the Drawing

(**BLUE**) and by back circling (clouding) and revision triangles on a freezable revision layer. Revisions shall be dated and initialed. After submission to, and approval by NYPA, Record Drawings shall be issued Revision 0 (zero).

Drawings and packages shall be fully coordinated and referenced (“to” and “from” associated drawing(s)) within types (e.g. “S”) and across types (e.g. “S” to” E” to “W”) and reference specific Vendor Drawings.

Drawing scale and font sizes shall be suitably selected. Normal minimum font size is 1.0; absolute minimum is 0.9 only with prior NYPA approval. Drawing title blocks, numbering system and dimensions shall conform to NYPA standards. Overhead conductor drawings shall be prepared on PLS CADD. Other design drawings shall be prepared in AutoCAD. Submittals shall include full size drawings, 11”x17” plots, plus dwg and pdf files.

Drawings shall incorporate NYPA convention drawing colors. Revisions to NYPA drawings or drawings related to installed Work shall utilize NYPA colors: **GREEN** = delete/remove/demolish; **RED** = add; **BLUE** = design / construction note that will not be included on the Record Drawings.

For an example Drawing Index, the STL region index includes drawing types: S – Schematic; E – Elementary; W- wiring; C – Conduit; A – Arrangement; L – Lighting; M – Miscellaneous; N – Numerical; T- Transmission. See Appendix A, STL – FDR Project Drawing Index.

Each drawing category shall include a symbol legend. Plan, elevation, equipment, and associated detail drawings shall be scaled. Drawings shall accurately depict the Work.

4.1.1 Schematic Drawings

“S” drawings shall be complete including equipment specification information, equipment IDs, and ratings. Include one-line diagrams for power system, metering, and relaying diagrams, low voltage AC and DC systems, grounding; system, phasing, and logic diagrams; relay setting sheets, protective functions, and communications. Panel schedules shall identify the loads associated with each breaker. Panel breaker loads, maximum continuous loads per phase, etc. shall be included in the calculations.

4.1.2 Elementary Drawings

“E” drawings shall depict instrument, component, and terminal block point to point connections with cable, terminal, and conductor identifications depicted. Reference origin and destination device and reference drawings shall be identified. Show detail including internal device diagrams; synchronizing; DC systems; breaker, breaker failure, MOD control; watt-hour metering; sequential event, and digital fault

recorders; transformer, bus, line, breaker failure, backup relaying, disconnect switches; AC elementary; annunciator; drainage and dewatering; air conditioning; lighting; control, and miscellaneous.

4.1.3 Wiring Drawings

“W” drawings shall depict all point to point wiring connections, terminal blocks, relay panel wiring, cabinet wiring, etc. Cable, conductor, and terminal identification / labels shall be depicted. Detail including relaying, metering, synchronizing, sequential event recorder, digital fault recorder, microwave system, security, HV circuit breakers, switches, MODs, station service, fire protection, control building power distribution, ATSS, communication, lighting control, and miscellaneous circuits.

4.1.4 Conduit Drawings

“C” drawings shall identify and locate all installed conduit. Subsurface locations shall be depicted with dimensional accuracy. Stub-ups shall be dimensionally located relative to served equipment or structure. Conduit size, material, and labeled ID’s shall be included, along with continuation drawing reference. Cable tray routing and contents shall be detailed. Conduit and cable schedule, and cable tray schedule shall identify conductor IDs, type, number, size, and equipment served.

4.1.5 Arrangement Drawings

“A” drawings shall completely depict structures and equipment installations to scale in plan, elevation, and/or sectional views sufficient to convey full spatial information. Dimensional information shall be sufficient to allow ready interpretation of available space, working, and clear spaces.

4.1.6 Lighting Drawings

“L” drawings shall locate and identify lighting including identifications of fixtures, electrical and control circuits, and conduit. Lighting distribution with lumen levels at surface, working platform levels and equipment shall be depicted.

4.1.7 Miscellaneous Drawings

“M” drawings are as required, not included in other types. Consult NYPA for items to be included.

4.1.8 Numerical Drawings

“N” drawings include switchyard topography, grading, plan, foundations, switchyard steel, building architectural, steel, and concrete, heating and ventilation, plumbing, and fire alarm drawings.

4.1.9 Transmission Drawings

“T” drawings shall depict attachment facility transmission level conductors, equipment, structure, and grounding. Drawings include location plan, clearing ROW, ROW map, plan, and profile, wood structures, steel towers, miscellaneous details, counterpoise and grounding, site access, stringing tables, obstacle lighting, phasing, and line data.

4.1.10 Cable and Conduit Schedules

The Cable and Conduit schedules shall be complete and fully coordinated with the drawings. Depict data including cable ID's, endpoints, wire sizes, conduit, and/or cable tray ID's.

4.2 Specifications

Purchase and construction specifications shall be in CSI or approved format, detailed and complete. Components of the Work shall be sufficiently specified as to minimize installation contractor decision process.

Examples (as well as NYPA requirements):

- Low voltage fusible and circuit breaker over current protective devices shall be identified with specificity, including voltage, ampere, interrupting capacity ratings, protective, and dimensional class. Fuse holders shall include rejection feature for class R, J, L, etc. Low voltage renewable fuses or one-time fuses utilizing zinc link fusible elements shall not be permitted.
- 120 V outlets mounted on outdoor surfaces shall be in weatherproof box equipped with clear covers, individually protected by GFI receptacles rated 20 A.
- Electrical conductors shall be specified type, stranded copper, gauge or kCMIL, insulation, and jacketing. Thermoplastic insulation or PVC insulation or jacket is not acceptable in the switchyard or Control Building.
- Fire extinguishers shall have effective rating categories and capacities specified.

4.3 Record Drawings

Record Drawings shall faithfully reflect the As-Built installation.

As the construction proceeds, the Developer shall maintain detailed As Built Drawings (Construction Yellow Lines) of each drawing. Developer shall maintain Construction Yellow Lines including contemporaneously keeping up to date As Built Drawings that yellow line /confirm that the design matches the As Built condition with date and initialing showing a progression of completed components; and/or showing changes using **RED**, **GREEN**, and **BLUE** notations with date and initial. Any adjustments to design documents caused by engineering or field changes shall be incorporated into the As Built yellow lines (including attaching the ECN or FCN and yellow lining) and subsequently incorporated into the Record Drawings. The As Built components and materials shall be the components and materials installed. Developer shall submit the As Built Drawings (yellow lines), including BOM, Cable, and Conduit schedules, etc. prior to energization of the switchyard by NYPA.

Record Drawings shall be CAD drafted using the As Built Drawing information. Record Drawings and specifications shall be signed and sealed by the EOR.

Developer shall require the EOR /EOR representative to continuously monitor construction or make periodic, sufficient site verification inspections to assure the installation reflects the design and enable EOR to issue Certificate(s) of Completion.

A Developer surveyor shall survey the As Built locations of items including grading, access roads, structures, manholes, equipment, buildings; underground structures, underground conduit route and elevations, drainage routes and inverts for the purpose of accurately depicting the information on the Record Drawings. Microwave towers shall be surveyed including foundation elevation and tower location.

Arrangement drawings shall reflect to scale, structure, actual equipment installed, locations, and spatial relationships, both in plan and elevation views.

Elementary and wiring diagrams shall be verified to ensure they reflect installed conditions including cable and wire termination labels, and terminal IDs.

Developer shall remove or finalize interim notes prior to submittal of Record Drawings.

Developer Record Drawings shall meet the following criteria:

TYPE I – Drawings originated and drafted by Developer

- Work shall be **BLACK** color
- Clouding, revision triangles, and notes (**BLUE**) shall be removed

- Drawing Revision Block shall indicate Rev 0, “Record Drawing”, be initialed, and dated. Record Drawings shall be signed and sealed with PE stamp by the EOR.
- Transmittal of Record Drawings to NYPA:
 - A. Electronic copies provided in DWG file format. DWG files shall have indication in the seal box that the drawing has been sealed, coordinate with NYPA. Drawing file is named the drawing number without revision number added.
 - B. “Wet” signed and sealed full size copy and PDF thereof.

TYPE II – NYPA SK1 drawings supplied to Developer by NYPA

- Work shall be shown: additions in **RED** or in **BLACK** and back circled; deletions **GREEN**, or in **BLACK** and back circled.
- Revision triangles and notes (**BLUE**) shall be removed
- Drawing Revision Block shall indicate Rev xa, “Record Drawing”, be initialed, and dated. X in xa references the revision number that was provided to Developer by NYPA; a in xa references the next alphabetic character in the series incremented one from the last alphabetic character used by Developer. Record Drawings shall be signed and sealed with PE Stamp by the EOR.
- Transmittal of Record Drawings to NYPA:
 - A. Electronic copies provided in DWG file format. DWG files shall have indication in the seal box that the drawing has been sealed, coordinate with NYPA. Drawing file is named the drawing number without revision number added.
 - B. “Wet” signed and sealed full size copy and PDF thereof.

TYPE III – Drawings that have been produced by NYPA For Construction and provided to Developer for use on the project

- Work shall be shown: additions in **RED** or in **BLACK** and back circled; deletions **GREEN**, or in **BLACK** and back circled.
- Revision triangles and notes (**BLUE**) shall be removed
- Drawing Revision Block shall increment the alpha character indicating “Record Drawing”, initialed, and dated.

- Record Drawings shall be signed and sealed with PE Stamp by the EOR.
- Transmittal of Record Drawings to NYPA:
 - A. Electronic copies provided in DWG file format. DWG files shall have indication in the seal box that the drawing has been sealed, coordinate with NYPA. Drawing file is named the drawing number without revision number added.
 - B. “Wet” signed and sealed full size copy and PDF thereof.

4.4 Turn Over Packages

Turn over packages (TOPs) include Permit / Construction TOPs (CTOPs) and Equipment TOPs (ETOPs).

The Developer shall transmit the construction turn over and construction QA/QC documentation in the CTOPs; equipment information for NYPA Operations and Maintenance in the ETOPs. The TOPs shall contain all pertinent information. Developer shall provide CTOPs and ETOPs as hard copy, pdf files, and in MS Access database(s) or other approved format. The ETOPs shall be coordinated to the Equipment List and BOM. The database shall allow drawings and documents associated with any particular equipment or BOM item to be easily accessed, retrieved, and printed.

The following lists are indicative of contents. Developer shall submit content early during the project design phase.

CTOP:

- All permits, variances, licenses, access roads, rights of way, structures, and allowed usage.
- Certificates of Inspections including: Electrical, Structural, Fabricator, Fire Alarm, Board of Underwriters.
- Testing Certifications, Soil Compaction, Concrete testing, etc. (compilation of reports)
- Certificates of Special Inspections
- EOR Certificates of Completion
- Certificate of Occupancy from Authority Having Jurisdiction
- Field Testing documentation
- QA/QC checklists (compilation of reports, CIMP checklists, etc.)
- As-Built Construction Drawing List

- Field Change Request (FCN)/ Field Change Notice (FCN)/ Design Change Notice (DCN) list
- QA/QC Nonconformance List / Documentation of resolutions

ETOP:

- Equipment Specification
- Equipment Purchase Order documentation
- Factory Test documentation, Field Installed (Baseline) Test data.
- Pictures of Equipment Nameplate showing Model and Serial Numbers and picture of Equipment Label
- Vendor product documents including drawings, specifications, operation and maintenance manuals, recommended spare parts lists, Representative and Factory contact information. Vendor Drawings shall be EOR approved and annotated to indicate supplied equipment configuration: e.g. strike through components not supplied; highlight with arrows/ stamps for included components.
- List of Developer provided spare parts, PO, PO numbers, Part numbers, supplier, and costs.
- Programming manuals and documentation of as-supplied programming e.g. relay settings data.
- Warrantees, maintenance, and/or service agreements, expiration dates, contact information.

5.0 EQUIPMENT AND MATERIALS

Developer shall submit equipment and materials.

5.1 Power Circuit Breakers

- A. HV circuit breakers shall be dead-tank, SF₆ type.
- B. The continuous and short-circuit current rating of the circuit breakers shall be determined by NYPA for each specific project.
- C. Circuit breakers shall be equipped with two trip coils.
- D. The circuit breakers shall be supplied with a minimum of 18 normally open and 18 normally closed auxiliary contacts.
- E. The circuit breaker selector switch shall have a minimum of 10 decks, each with 4 contacts.
- F. Circuit breaker control cabinets shall be equipped with local / remote switch and telephone extension jack.
- G. Power Circuit Breakers shall comply with NYPA ES-103-01.

5.2 Disconnect Switches

Motorized Group Operated Line Disconnect Switches and Manual Gang Operated Circuit Breaker Disconnect Switches

- A. Motorized and manual line and breaker disconnect switches shall be designed operate in all weather conditions, including icing conditions.
- B. Line disconnect switches shall be provided with manually operated grounding switches.
- C. The site specific continuous and momentary current ratings of disconnect and grounding switches will be specified by NYPA.
- D. Motorized and manual disconnect switches shall be provided with external limit switches with a minimum of 6 normally open and 6 normally closed auxiliary contacts. The LSs shall be used for indication and/or relaying purposes.

- E. Line disconnect switches and grounding switches shall have “open” and “closed” position indication located on the operating mechanism.
- F. Disconnect Switches shall comply with NYPA ES-103-02.

5.3 Potential Transformers

- A. Potential transformers shall be provided for relaying and/or metering.
- B. Both capacitance coupled and magnetically coupled units are acceptable. However, for revenue metering only magnetically coupled potential transformers shall be used.
- C. If capacitance coupled transformers are used for an application that requires periodic CCVT recalibration, then these transformers shall be used only if a set of magnetically coupled transformers is installed at the switchyard and can be used for in-service comparison.
- D. Developer shall submit accuracy class and burden of each potential transformer.

5.4 Current Transformers

- A. Current transformers shall be bushing type, window type or free-standing installed for relaying and/or metering.
- B. The accuracy class and burden of the current transformers shall be as follows:
 - 1. Relaying Accuracy Class shall be in compliance with $V_k \geq C$ 800V at maximum tap.
 - 2. Metering accuracy class CT shall typically be 0.15 B 1.8. Extended range accuracy Class CT performance may be required.

5.5 Surge Arresters

- A. Surge arresters shall be station class, metal oxide, gapless. The Surge arrester ratings shall be determined by the Insulation Coordination Studies.
- B. Surge arrestors shall comply with NYPA SR-101.

5.6 Power Transformers

- A. The step-up transformer shall be supplied by the Developer and installed outside the perimeter of the NYPA switchyard.
- B. The step-up transformer shall meet the following criteria:
 - 1. The high voltage winding shall be delta connected, unless otherwise instructed by NYPA;
 - 2. The high voltage rating shall match the NYPA system voltage;
 - 3. No-Load tap changer is usually acceptable. There may be specific instances where load tap changer shall be required. Developer shall coordinate with NYPA early in the design.
 - 4. Developer shall submit the transformer MVA rating and impedance p.u. value.
- C. The step-up transformer should meet the following criteria. If the installation is on property to be owned by NYPA the transformer shall:

Transformer shall be oil-filled. The oil shall be certified PCB free. An oil containment system meeting regulatory requirements for oil filled equipment in the Developer's switchyard shall be provided. The fluid containment system shall be designed to provide for rain, ice, and snow accumulation of the location. Drainage piping from such containment shall be to "daylight" and shall not be perforated piping.

- 1. Noise generated by the transformer and accessory fans, shall be within NEMA/IEEE limits.
- 2. Power Transformers should comply with NYPA ES-102-01. Section 1.12, A – E shall not apply.

5.7 Control Building

- A. Developer shall provide a switchyard Control Building. The Control Building shall be a single story building with layout to neatly accommodate equipment and accessories, allow access for maintenance of equipment, and shall contain layout and allocated space for future equipment associated with expansion of the switchyard.

- B. The following Control Building spaces shall be provided:
- Heated vestibule, approximately 6'x8'
 - Equipped kitchen / break room, minimum 14'x14'
 - Storage room, minimum 12'x12', with interior and exterior doors
 - Control room/work room, minimum 14'x14'
 - Primary and Secondary Relay Rooms (each fire rated)
 - Primary and Secondary Battery Rooms (each fire rated)
 - Emergency generator room
 - Bathroom with shower

The equipment layout shall provide proper working clearances and clear space.

- B. The control building will house the primary and secondary relay panels located in separate primary and secondary relay rooms, communication and carrier cabinets, monitoring equipment, SCADA cabinets, and fault and event recorder cabinets. The batteries, battery chargers, low voltage switchgear, and AC and DC distribution panels will be located within the building.
- C. Provide a single handicapped design bathroom with shower. Provide hot and cold water. Provide sewer connection to an on-site sewage treatment system or local POTW (Publicly Owned Treatment Works). Hot water shall be provided by a tank-less water heater.
- D. Potable water shall be provided, including connection to municipal water source and/or well. If well, test water for determination of disinfection, chlorination or other treatment system options. Submit recommendation and provide systems.
- E. Cables entering the building from the switchyard shall be routed below the Control Building floors in trenches / cable trays and/or via overhead cable trays. If below floor, the relay, terminal, RTU, etc. cabinets shall be fastened to structural steel frames at the top of the trenches to provide wire routes from below.
- F. All conduits penetrating the exterior walls of the building shall be plugged with duct seal to preclude condensation associated with convection within the conduit.
- G. Overhead interior cable trays shall be routed above the equipment.

- H. Building and structure design parameters including importance factors, component importance factors; dead, live, wind and snow loads; seismic, and site class shall be in accordance with the NYSBC, IEEE, and standards and codes.
- I. The Control Building shall be provided with fire detection, alarm, and suppression systems. All spaces of the control building shall be provided with the fire detectors. The fire alarm system shall be capable of local and remote indication with local acknowledgement.
- J. Fire detectors shall be early warning smoke detectors of the photoelectric or ionization type. The alarm system shall provide local audible/visible annunciation in and exterior to the Control Building. The local fire alarm panel shall be connected to the RTU to provide remote alarm. Circuits shall be electrically supervised. The smoke detection system shall be installed in enclosed areas/buildings which house cabling, breakers, control cabinetry, switchgear, transformers, or other electrical equipment of low, high, or control voltages. Installation shall conform to latest edition of ANSI/NFPA.
- K. The fire alarm panel shall be provided with battery back-up with a minimum capacity of 24 hours per NFPA.
- L. Floor and wall openings in the Control Building shall be sealed with a UL listed penetration detail to maintain the fire rating of the floor or wall. Conduit penetrations shall be sealed at ceiling, floor, and wall.
- M. The HVAC system for the control building shall be designed to provide heating, cooling, and ventilation air. Ambient design conditions shall be as specified in the NYSBC. Outside design temperature and conditions shall be per ASHRAE for the location of the switchyard. HVAC equipment shall be sized for 120% of design load. HVAC equipment shall have multiple units in a lead-lag control arrangement. Space heaters shall be provided to back up the HVAC system(s).
- N. Battery rooms shall be provided: primary and secondary. The HVAC system for each battery room shall be designed in accordance with IEEE and NYS Fire Code to provide ventilation air. This air flow shall be factored into the heating and cooling load calculations. Provide ventilation fan with spark resistant construction and explosion proof motor. Doors to any battery room/area shall be equipped with safety signs, prohibiting smoking, sparks, or the use of open flames per ANSI. Battery room fire suppression shall be provided by portable non-conductive dry chemical fire extinguishers minimum Classification 4-A:60-B:C.
- O. HVAC equipment shall be electric, self-contained, pre-assembled, pre-wired, and thermostatically controlled.

- P. A Control Building security system shall be integrated with the switchyard security system described in Section 7. HVAC, security, and fire system operation, trouble and failure alarms shall be monitored via the RTU. High and low temperature alarms in each of the Primary and Secondary Relay and Battery Rooms, hydrogen alarm, eye wash or emergency shower activation and other alarms (e.g. sump high level) shall be wired to the RTU.
- Q. Eye wash stations and emergency showers shall be provided in accordance with IEEE for eye wash and ANSI for eye wash and emergency showers. Submit locations, at least one in each battery room. Each station shall have a collection reservoir for used fluid and dry contacts for alarm connected to the RTU. The eye wash station shall be self-contained (Fend-All 2000 or approved equal) or permanently plumbed from the potable water source. Self-contained units shall be gravity operated, complete with catch tank. For a permanently plumbed unit, provide floor drain and a source of tepid water. The source of tepid water shall be designed for a 15 minute supply period. Mixing valves and anti-scald devices shall be provided.
- R. If the Control Building is finished with a flat roof, the roof shall be provided with membrane construction. Provide 30 year warranty. Caulked joints in a prefabricated building roof slab configuration are not acceptable.
- S. Control Building exterior doors shall be furnished with Best Access Systems construction key cores for insertion of permanent key cores by NYPA Security. Or equal is not acceptable.
- T. Developer shall provide automated external defibrillators (AEDs), wall mounted First Aid kits, Key Boxes, and furniture. NYPA shall supply current AED and First Aid kit specifications.

5.8 Power Cables

- A. Cables shall be suitable for underground and above ground use in wet and dry service conditions.
- B. The feeder ratings to the station service transformers shall be determined based on recognized standards and Good Engineering Practice for 133% insulation level. Cables shall be rated 600V for AC power circuits 600V and below and for 125V DC and below.
- C. Medium voltage (>5KV) cables shall be: Class B, 90°C, concentric-lay-stranded copper conductor, ethylene propylene rubber (EPR) insulation,

helically applied copper tape, low smoke, zero halogen thermo-setting jacket. Conductor and insulation shields shall consist of an extruded layer of a semi-conducting thermosetting compound compatible with the insulation. The copper tape shall be capable of carrying the line-to-ground fault for the time needed by the circuit protective device to clear the fault without exceeding 200°C. Medium Voltage Power Cable shall comply with NYPA ES-105-00.

- D. 600V rated cables shall be: Class B, 90°C, concentric-lay-stranded copper conductor, flame resistant ethylene propylene rubber or cross-linked polyethylene insulation, low smoke, zero halogen thermo-setting jacket. Thermoplastic or PVC insulation is not acceptable. Low Voltage Power Cable shall comply with NYPA ES-106-00.

5.9 Control and Instrumentation Cables

- A. All multiple conductor cables for AC and DC service shall be rated minimum 600V AC and shall be as specified in Section 5.8 D above.
- B. In addition to A., Control and instrumentation cables installed in HV (115kV and above) switchyard shall be shielded with 5 mil helically wrapped tinned copper tape, no less than 25% overlap, with #16 or #18 drain wire.
- C. Terminations shall be nylon insulated (no PVC) compression, ring type, UL listed.
- D. Instrumentation Cable shall comply with NYPA ES-106-01.

5.10 Cable Trenches, Conduits, and Trays

- A. Underground raceways should be the primary means to run power and control cables to yard equipment. The raceway system should be comprised of direct buried conduits from equipment to a cable trench system containing cable trays leading to the Control Building.
- B. Acceptable construction for the cable trench systems shall be either:
 - 1. Cast-in-place concrete construction
 - 2. Precast concrete trench

Trenches shall be provided with installed access ladder rungs.

- C. Cable trenches shall be arranged such that the routing follows the basic coordinates of the switchyard. Provision for storm water drainage, e.g. French drains, shall be provided. Segregation barriers shall be provided where it is necessary to run cables of different signal levels in the same tray or trench. HS-20 rated trench / galvanized covers shall be provided. Minimum trench inside clear dimensions shall be 4' height x 4' wide. Same minimum dimensions if cable trenches are provided under the floor in the Control Building.

If cable trenches are provided under the floor in the Control Building, they shall be dry bottom. Slope to sump and provide discharge piping. If water infiltration is encountered, Developer shall install sump pumps.

- D. Functional separation criteria for conduit runs are that power, control, primary relaying and secondary relaying cable classes shall be routed in dedicated conduits until they reach the pertinent cable trays, as described below. Power cables above 600V shall be run entirely in direct buried conduit outside the cable trenches.
- E. Aluminum ladder type cable trays shall be installed in the trench for cable placement. The cable segregation criteria in a tray shall be as follows:
1. Station Service conductors;
 2. All other 600 V power cables (operating at 480/277V, 120/208 V, 120-240 V);
 3. 120 VAC control, PT, and CT wiring;
 4. 125 VDC (or less) power and control (less than 20 amperes);
 5. Instrumentation, low voltage (24VDC or less) discrete inputs, analog signals (4-20mA); Communications, telephone, fiber, Ethernet, etc.;

All cables associated with fire detection, alarm, and suppression systems shall occupy a dedicated raceway.

In addition, cables shall be separated as required by NPCC, NEC, IEEE, and codes and standards.

- F. Cable trays shall have bonding jumpers to maintain continuity of the ground path.
- G. Underground conduits in the switchyard shall be buried at least 24" below finished grade. Conduits shall be PVC with rigid steel stub-ups, or rigid galvanized steel.
- H. Conduit exposed in the switchyard shall be rigid galvanized steel. Indoor and outdoor conduits shall be labeled per the Conduit Schedule, see

section 5.20.4. Watertight conduit fittings shall be used at outdoor junction boxes and terminal cabinets.

- I. Where liquid tight flexible conduit is used, provide bonding bushings and external bonding jumpers.
- J. Pull boxes or manholes shall be spaced so that allowed cable pulling tension and sidewall pressure are not exceeded. Conduit elbows, pull-box dimensions, and manhole openings shall be such that minimum cable bending radius is not violated. The following parameters shall be determined based on pertinent standards and manufacturer's recommendations:
 - 1. Allowable pulling tension
 - 2. Allowable sidewall pressure
 - 3. Minimum bending radius
- K. Cables shall be continuous runs. Pull boxes, cable trays, trenches, LB's, etc. shall not be used for locating splices, even if listed for such service. Submit specific proposed exceptions. Conduit runs shall be sloped to provide drainage into hand holes or cable trenches.
- L. Provide spare conduits with pull chords:
 - 1. At each HV Circuit Breaker – one 2" to each of primary, secondary trench
 - 2. One 1-1/2" from gate phone location to Control Building telephone board.
 - 3. As appropriate

5.11 Lighting

- A. Interior lighting shall be fluorescent. Exterior wall pack and switchyard lighting shall be timer/photocell controlled with manual override, pulse start metal halide, suitable for ambient conditions with re-strike quartz lamp. Lighting shall be high efficiency with low harmonic distortion.
- B. Design drawings and calculations shall be submitted showing illumination levels for each area, calculation methods (not on drawing itself), design and installation details, and bill of materials.
- C. Lighting shall fulfill the following functions:
 - 1. Outdoor general lighting
 - 2. Indoor general lighting

3. Local lighting
 4. Emergency lighting
 5. Security
- D. The switchyard shall be illuminated by general lighting and security lighting. The Control Building shall be illuminated by general, emergency, and local lighting.
- E. The levels of illumination shall be:
- For outdoor general lighting 10 fc ground level
Illumination level at ground level about 3' outside the switchyard fence shall be less than 0.5 fc (coordinate with surveillance camera equipment)
For indoor general lighting 30 fc ground level
For local lighting of switchboards, metering, and control panels in the Control Building..... 50 fc front panel @ 4'
Emergency light (ground level) 15% of general lighting
Security lighting at the fence..... See Section 7
- F. Exit and directional signage shall be provided with battery back-up (UL listed, minimum 90 minute capacity), or powered from the UPS panel - in accordance with NYSBC.
- G. Emergency lighting shall be provided in Control Building illuminated spaces. Emergency lighting shall be provided at the primary and secondary relay cabinet faces. The emergency lighting fixtures shall be UL listed with battery back-up for a minimum 90 minutes capacity or powered from the UPS panel - in accordance with NYSBC. Emergency lighting shall also be provided on the exterior of the building at each of the personnel exits.
- H. Lighting shall be calculated in accordance with accepted standards, namely: general lighting, by “zonal cavity” method; local lighting, by “point-by-point” method; switchyard lighting, by “graphical method.”
- I. Lighting fixtures and lamp types are:
- Control Building.....Fluorescent, warm white
 - SwitchyardMetal Halide with re-strike quartz lamp
 - Battery roomVapor-proof or explosion proof

5.12 AC Station Service Power

- A. The entire AC station service system shall be considered essential.
- B. The AC station service shall be configured for reliability. Reliable supplies shall be configured in a “cascade” using two break before make automatic transfer switches (ATSs) equipped with maintenance bypasses. ATS signals shall be connected to the RTU. Primary power shall be Developer supplied power derived from Developer’s HV bus via a transformer (or from a transformer in the switchyard), first backup from local utility source and second backup from a Developer supplied emergency propane fueled generator. This configuration assumes the Developer’s substation is adjacent to the NYPA switchyard.
- C. Voltage shall match the local utility service voltage. Sources shall be 480V, 3-phase, 4-wire, grounded; 120/208V, 3-phase, 4-wire, grounded; or 120/240 V, 1-phase, 3-wire, grounded.
- D. AC distribution panel boards shall be main breaker equipped, configured with Critical and Non-Critical circuits in separate panels (Red Dot and Green Dot per NYPA CPP-1). Coordinate with NYPA.
- H. The station service kVA sizing shall be calculated based on the calculated maximum AC load plus a 25% margin for future expansion. Each source, transformer or emergency generator, shall be rated to supply the entire AC station service load plus margin.
- I. A battery backup UPS system and panel board shall be provided for AC loads sensitive to switching transients including: fire alarm system, HMI, security system, site computers (provide labeled outlet receptacles at various locations), SER and DFR computers, emergency lighting (if included in design), and loads that do not tolerate break before make transfer (e.g. radios, other computer equipment). Developer shall provide 8 hour, plus 40% load margin in the UPS system backup load supply capability. The UPS shall comply with NYPA SR-106. If desired, the Developer design may power the UPS from the primary / secondary 125V battery set(s), appropriate load to be included in that sizing calculation.
- J. Developer shall provide Arc Flash studies and labeling in NYPA standard format for enclosed alternating current switches, circuit breakers, power distribution panels, and other accessible equipment operating at or below 35kV without limitation to level of personal protective equipment. Calculations per NFPA 70E shall be submitted.

5.13 DC Station Service Power

- A. The DC station service arrangement shall consist of two complete systems, each consisting of a nominal 125V battery, battery charger, and distribution panel. The two systems shall normally operate isolated, one dedicated to primary relaying and the other to secondary relaying; plus other station service loads. The systems shall be ungrounded, floating. Protection shall be appropriate for a floating system including ground detection alarm. Batteries for Station Service and Microwave communication shall be vented (flooded) lead acid type.
- B. Each battery shall be sized to provide the entire calculated switchyard DC power load plus 10% for future expansion. In addition, the AH capacity shall take into account the battery aging and temperature correction, and shall be based on 8 hour discharge rate providing 8 hours of backup. Station Service Batteries shall comply with NYPA ES-107.
- C. A DC system switching arrangement shall be provided such that a battery may be taken out of service for maintenance or testing while the other is in service, providing for entire station load in accordance with NPCC.
- D. Each battery bank shall be installed a dedicated battery room within the Control Building.
- E. Sizing shall be calculated according to IEEE recommended practices. The sizing of the switchyard batteries shall include the following loads:
- Momentary loads due to the simultaneous operation of a group power circuit breakers (for example, bus differential protection) and inrush currents such as those from a motor
 - Continuous loads such as panel lights, holding coils, carrier equipment transmitters, and receivers, microwave, protective relaying, and SCADA for 8 hours minimum
 - Connected DC emergency and exit lighting
- F. For battery sizing purposes, the duration of continuous loads and emergency lighting shall be taken as 8 hours.
- G. The battery chargers shall be of the electronic type. The DC output capacity of each charger shall be such that it is capable of recharging the battery at the highest system voltage in 16 hours while serving the connected continuous loads. Battery chargers shall comply with NYPA SR-107.

- H. Ventilation and safety equipment shall be provided for the battery rooms.

5.14 Emergency Power

- A. Developer shall supply a propane fueled emergency generator. This generator shall be sized to supply the AC station service distribution panels load plus margin at continuous operation rating. Generator operation, Fire Suppression System, etc. trouble and failure alarms shall be monitored via the RTU.
- B. Critical exhaust silencer and sound attenuating enclosure shall be provided.
- C. Starting battery system including a charger capable of supplying generator auxiliary load and charging the battery shall be provided.
- D. Developer shall provide for periodic testing of the emergency generator. Periodic testing shall be performed either by onsite personnel, programmable automatic timer, or by NYPA via supervisory control signals from the RTU. Developer shall provide controls for automatic testing and an integrated stepped load bank sized for generator rated load.
- E. An underground propane tank shall be provided sized for 3 days of continuous operation at generator rated load. Provide propane heater system to ensure reliable fuel supply during extreme weather conditions at site.
- F. The generator shall be located in the Control Building in a separate room provided with minimum 4' maintenance clearance on minimum 3 sides around. Provide a dry agent Fire Suppression System. Provide single interior access door and double exterior access door.

5.15 Bus and Bus Support

- A. Aerial bus shall be rigid, high strength ANSI Schedule 80, Alloy 6063-T6 or equivalent.
- B. Strain bus extensions may be installed to relieve stresses on potheads and equipment terminals. The strain bus shall be All Aluminum Conductor (AAC) or All Aluminum Alloy Conductor (AAAC) and shall be of compatible size.

- C. Bus size shall be determined considering the continuous current rating of the project and other parameters including short circuit current, ambient temperature and maximum temperature rise, in accordance with IEEE standards. Minimum bus size shall be 4”.
- D. Developer shall calculate the number of supports based on factors such as fiber stress, deflection, cantilever strength, wind induced vibrations, etc. in accordance with IEEE standards.
- E. Provisions shall be made for thermal expansion of bus. For each length of the rigid bus Developer shall show the type of fitting at each bus support (fixed-bus or slip-fit) and the location and type of bus couplers.
- F. All horizontal bus runs shall have damping cables placed inside. Do not drill weep holes.
- G. The length of a continuous bus shall be limited to 100’.
- H. Developer shall submit bus calculations.

5.16 Insulators

- A. Insulators shall be high strength. Extra high strength insulators shall be used if site specific conditions warrant their use. Coordinate with NYPA.
- B. Insulators shall be in unit stacks in accordance with NEMA. Stacks of different cantilever strength shall be identified.
- B. Station post insulators shall have a minimum of two stacks. All stacks shall be of same cantilever strength.
- D. Post-type insulators shall not be used with strain bus, except as stand-off insulator, and only with prior approval from NYPA.
- E. Strain type insulators shall be used to terminate the incoming overhead lines.
- F. Suspension type insulators shall be used where necessary with strain bus for under-hung installation.
- G. Polymer insulators shall not be used for any application.

5.17 Corona Control

- A. The design and construction of the switchyard shall take into consideration means to minimize the audible noise induced by frequency and corona. Corona-free hardware shall be used. Sharp corners on the bus conductors shall be avoided and bolts shall be kept short.
- B. All 345 kV switchyard hardware shall be rated for EHV application.
- C. The switchyard bus in a 345 kV switchyard shall be fitted with grounding studs for corona control.

5.18 Surge Counters

Surge counters shall be provided on surge arresters.

5.19 Acoustics

Developer shall design to ensure that the noise generated by equipment including transformers, corona, and generators meets local and national standards.

5.20 Electrical Identification

Developer shall install identification on items including structures, equipment, cable trays, conduit, cable and wire. Identification shall be in strict coordination with the drawings. Developer shall coordinate requirements with NYPA. Electrical equipment, relays, conduits, cables, and conductor terminations shall be labeled and identified as to function and designation. Sample labels of each type shall be submitted.

5.20.1 Equipment Labels

Equipment and device nameplates shall be engraved laminated phenol resin. Equipment shall be labeled with equipment number and identification. Items including relays, instruments, and control switches shall be labeled to show device designation and function.

5.20.2 Cable Identification

Each single or multi- conductor cable shall be labeled at both ends. Cables shall be tagged within the termination enclosures using approved cable tags with lettering minimum 3/16" tall. Cable tags shall be located near the end of the

jacket, at a safe distance from terminations, attached using plastic wire tie, and not be concealed. In addition to cable tags, termination labeling is required, see below.

5.20.3 Conductor Identification – Termination Labels

Conductor terminations, regardless of use, shall be identified. Each termination shall have a sleeve identifying the terminal point of the conductor. Conductor identification sleeve material shall be approved. Lettering for conductor marker sleeves shall be 1/8" tall.

5.20.4 Conduit Identification

Developer shall label each end of conduits with stamped 19-gage brass tags affixed by stainless steel wire ties. Tags shall be 1.50" diameter with 3/16" diameter top hole. Conduit number shall be stamped with 3/16" tall letters.

6.0 CIVIL, STRUCTURAL, AND MECHANICAL

Site selection and development is critical to the design of the switchyard. Developer shall consult and coordinate with NYPA concerning site selection. Developer selected site shall be suitable for the intended purpose. Plot, layout, and availability of real estate (future purchase) shall take into account that available plot area for future expansion (additional bay of HV circuit breakers) is required. The switchyard shall not be “boxed in”. Sites requiring extensive cut and fill should be avoided.

6.1 Soil Conditions

- A. Developer shall perform geotechnical investigations to characterize the site soil bearing capacity, resistivity, water table, bedrock depth, etc. Developer shall submit comprehensive geotechnical investigations reports. The report(s) will be the basis of site and soil classification for seismic, structural, and other design aspects. The Geotechnical Report recommendations shall be incorporated in the project structural drawings and specifications.

6.2 Limits of Construction

- A. The limits of construction, roadway centerline, right-of-way, easements, and tree protection zones shall be located and flagged prior to site grading and drainage operations.

6.3 Erosion Control

- A. Developer shall design and provide erosion control. If construction limits are modified, the installation of erosion control measures and tree protection fencing shall be re-established.
- B. Provide NYS approved barriers to trap sediment in runoff prior to runoff entering adjacent buffer areas.
- C. Side slopes adjacent to the roadway and the switchyard will be riprap armored or will be re-vegetated to protect side slopes. Riprap stone will be hard durable rock, angular in shape, and conforming to the USACE, “Hydraulic Design of Flood Control Channels,” EM 1110-2-1601.

6.4 Drainage

- A. Site drainage will be facilitated by grading the switchyard and access road or via discharge to an approved storm-water drainage system. Disturbed buffer areas will be re-vegetated with a seed mix conforming to NYSDOT Standards.

6.5 Site Surfacing

- A. Materials, application of aggregate surfacing, and the sampling and testing of aggregates shall comply with NYSDOT Standards. Aggregates shall be supplied from approved NYSDOT sources. Access road, on-site parking, and switchyard roads shall be paved. The top coat layer of asphalt paving shall be applied subsequent to the final utilization of heavy construction equipment on site.
- B. Immediately prior to surfacing, the sub-grade shall be at minus 3% / plus 2% of the optimum moisture content and shall be compacted to 95% of the maximum dry density. Soft, organic, and other unacceptable material shall be removed from the sub-grade. The aggregate surface course shall be uniformly graded crushed stone. The aggregate shall be placed in uniform lifts not exceeding 8 inches pre-compacted depth (6 inches in compacted depth).
- C. Field testing and sampling shall be provided by an independent testing laboratory retained by the Developer. The following tests shall be conducted for aggregate surfacing:
- Gradation tests prior to the delivery of materials onsite for each aggregate source. Sieve analysis shall be made for each sample according to ASTM C136
 - Two tests for laboratory density prior to delivery of material onsite for each aggregate source. Tests shall be performed according to ASTM D1557
 - In-place field density tests at average intervals of one test per 500 cu. yards. In-place density shall be measured per ASTM D2922.

6.6 Switchyard Structure Design

- A. Structural steel fabrication, erection, and connection design shall conform to the AISC "Specification for the Design, Fabrication, and Erection of Structural Steel", and the provisions included in this section. Steel shall be fabricated and shipped as hot-dip galvanized according to the latest version of the Standard Specification of Zinc Coating on Structural Steel. Steel members shall be cut from full-length stock. Unauthorized splices shall be rejected.
- B. Structural steel shall conform to the following:
- Wide flange shapes: ASTM A992

- Plates and other shapes: ASTM A36
- Square and rectangular tubing: ASTM A500, Grade B
- Round pipes and tubing: ASTM A53, Grade A
- Anchor rods: ASTM F1554, Grade 36
- Headed studs: ASTM A108
- Structural bolts and nuts: ASTM A325, A307, A394
- Hot-dip galvanizing of structural steel: ASTM A123
- Hot-dip galvanizing of bolts and nuts: ASTM A153

- C. Structural design criteria shall be provided on the drawings.
- D. Field connections shall be bolted using ASTM A325 high-strength bolts, unless noted otherwise. Welding shall conform to AWS D1.1. Welding electrodes shall comply with AWS. Concrete shall be set level. If leveling nuts are used, anchor bolts shall be designed for biaxial bending.
- E. Deflection calculations shall be based on service load conditions, not ultimate loads. The following deflection limits shall apply:
- Horizontal deflection of vertical members shall be limited to 1/100 of the vertical span.
 - Vertical deflection of horizontal members shall be limited to 1/200 of the span.
 - Horizontal deflection of horizontal members shall be limited to 1/200 of the span.
- F. The following deflection loading conditions shall be used to calculate deflections for structure racking purposes:
- NESC heavy loading;
 - No wind, 60°F.
- G. Loadings shall meet or exceed the following:

The loadings used in the design of structures shall not be less than those specified in the NESC for “heavy loading”. Structures, supports, etc. shall also be designed to withstand the following load:

1. Condition I (0°F) – NESC
Structures: 6.4 PSF Wind
Bus & Conductors: 4.0 PSF Wind and 0.5” Ice
2. Condition II (60°F) – NESC
Structures: Wind per NESC Rule 250C
Bus & Conductors: Wind per NESC Rule 250C and No Ice

3. Condition III (0°F)
Structures: No Wind
Bus & Conductors: No Wind with 1.5" Ice

The following overload factors shall apply to structures and equipment:

1. Condition I (NESC load factors for Rule 250B loads and Grade B construction)
2. Condition II

Transverse Wind Load:	1.25
Transverse & Longitudinal Wire Pull:	1.25
Vertical Loads:	1.25
3. Condition III

All Structures & Equipment:	1.25
Bus & Conductors:	1.25

Transverse loading shape factors shall be as per NESC Section 252B. Switchyard structures shall also be designed to withstand forces caused short-circuit current.

6.7 Foundation Design

- A. Foundation design shall usually be based on spread footings bearing on sandy, gravely native soils, bedrock, or compacted structural fill placed over native soils.
- B. The bottoms of exterior footings shall be placed at or below local frost depth (Geotechnical Soils Report or National Weather Service, NOAA Figure 1), but in no case less than 5 ft. Soft, organic, and other unacceptable material shall be removed from the sub-grade. If bedrock is encountered at site, or there exists other relevant geological soil condition affecting structural stability, then the recommendations of the Geotechnical Soil Report shall be followed for foundation design and foundation bedding. Depth of footings shall be determined from the exterior grade elevation adjacent to the foundation.
- C. Steel reinforcing bars shall be in accordance with ASTM Specification A615 – Grade 60 and shall be detailed, fabricated, and placed in accordance with ACI 315. Welding of reinforcing bars shall not be permitted. Welded wire fabric shall conform to ASTM A185-Grade 40. Concrete design shall conform to ACI 318 “Building Code Requirements for Structural Concrete.” Concrete shall have a minimum compressive strength of 3,500 psi at 28 days (ASTM Specification C94). For drilled

caissons, concrete shall have a minimum compressive strength of 3,500 psi at seven days and 5,000 psi at 28 days (ASTM Specification C94). Slump shall not exceed 4 inches; entrained air shall be 5-7%. Concrete shall be cured for a minimum of six days after placement.

- D. Minimum concrete protective covering for reinforcement shall be as follows:
 - i. Surfaces cast against and permanently in contact with earth: 3 inches.
 - ii. Formed surfaces in contact with earth or exposed to weather: 2 inches.
 - iii. Surfaces not in contact with earth or exposed to weather: 1½ inches.
 - iv. Portland cement shall conform to ASTM C150 Type I or II. Aggregates shall conform to ASTM C33.
 - v. The slab finish is very critical for certain structures. The transformer pads need to be level, true, and very smooth. These are to be finished to ACI 301 Class A tolerance.

6.8 Seismic Design

- A. The switchyard and Control Building shall meet NYSBC seismic design and installation requirements. Structures, equipment, equipment, piping, and ductwork shall be designed and constructed to resist the effects of earthquake motions in accordance with NYSBC, Chapter 16 “Structural Design”, Chapter 17 “Structural Tests and Special Inspections”. Use of SMACNA “Seismic Restraint Manual” is acceptable.
- B. Basic seismic design assumptions shall include (NYSBC references):
 - 1. Seismic Use Group III (Ref: 1616.2.3)
 - 2. Seismic Factor, $I_E = 1.50$ (Ref: Table 1604.5)
 - 3. Site Class = C (Ref: Table 1615.1.1)
- C. For seismic design purposes, meet the following minimum earthquake ground motion values (Figures 1615(1) and 1615(2)):

NYPA Site Location	S_s* (%)	S₁ (%)**
Ashokan	26.1	8.6
Blenheim Gilboa	25.1	8.6
Clark Energy Center	25.5	8.8
Crescent Dam	27.7	9.1
RM Flynn Project	28.0	7.9
Jarvis Project	25.5	8.8
Kensico Project	41.4	9.4
Niagara Power Project	30.6	6.8
St. Lawrence Project	70.3	15.8
Poletti Project	42.4	9.4
Vischer Ferry	28.2	9.2

* Maximum Considered Earthquake (MCE) of 0.2 sec Spectral Response acceleration 5% damping site class B.

** Same as above except 1.0 sec Spectral Response.

D. The Developer shall submit manufacturer’s complete design calculations for electrical equipment, related mechanical components, and support system. The manufacturer shall document the requirement noted in Section 1603.1.5 “Earthquake Design Data” and Section 1621.3.5 “Component Certification.”

E. Construction inspections shall meet the requirements noted in Section 1704 “Special Inspection”, specifically Section 1705.3 “Contractor Responsibility”, and Section 1707.7.3 “Component Manufacturer Certification.”

6.9 HV Circuit Breaker Platforms

Developer shall provide platforms at each HV Circuit Breaker cabinet for access and maintenance. Platforms shall be steel construction with Grip Strut or equal safety grating, concrete pad, stairs, removable handrails, and appropriate footers.

6.10 Mechanical

A. The mechanical design shall comply with the NYSBC, NYS Mechanical Code, NYS Energy Conservation Code, NYS Fuel Gas Code, and NYS Plumbing Code, plus codes and standards.

- B. The propane emergency generator shall be installed in accordance with NYS codes, and NFPA. Provide combustion, cooling, and ventilation air. Provide safety valves, shut-offs, regulators, and vents.
- C. All storm and sanitary drainage system shall comply with NYS and local plumbing codes and the Recommended Standards for Wastewater Facilities (also referred to as the “10 States Standards”).
- D. Ductwork shall be designed in accordance with SMACNA Standards.

7.0 ENVIRONMENTAL AND FLOOD HAZARD

- A. The switchyard shall be designed and constructed in accordance with Federal, New York State, and local regulatory requirements, including NYSBC, and NYS Fire Code affecting design, construction, and operation and maintenance of the facility.
- B. Developer shall submit to Agency and NYPA a SPDES General Storm Water Permit for storm water discharges from construction activities that disturb one or more acres of land and discharge to a surface water or municipal storm sewer. The Developer shall submit a Notice of Intent (NOI) form and a Storm Water Pollution Prevention Plan (SWP3) prior to the commencement of construction. The NOI and SWP3 shall be prepared in accordance with Permit for Storm Water Discharges from Construction Activity (GP-0-08-001) issued by the New York State Department of Environmental Conservation (NYSDEC).
- C. The Developer shall ensure that environmental considerations are identified and addressed in the design process. SF₆ gas emissions to the environment shall be minimized.
- D. The Developer shall identify and submit Environment, Health & Safety (EH&S) operational documents and plans.
- E. The Developer shall arrange for disposal of excavated soil and other waste materials utilizing approved disposal rules and procedure.
- G. Surfacing material such as crushed stone shall be well graded and washed with no fine materials which would cause dust. Crushed stone shall be granite type, shaped flat, to provide low hazard walking surfaces.
- H. The Developer shall provide freeze protection of control, relaying, and instrumentation components installed outdoors.
- I. The Developer's substation and NYPA switchyard shall be designed to contain potential oil spills in accordance with the SPCC rule of section 40 CFR 112, Part 613 of 6NYCRR, NFPA 30, and ANSI/IEEE 980-1984(R2001) Guide for Containment and Control of Oil Spills in Substations.
- J. The secondary containment shall be designed to contain the full volume of the oil, plus any water which may enter the area, including water from precipitation from a 25-year, 24-hour storm event.

- K. Any discharge from the oil containment area shall either be captured and held for disposal or shall be treated for discharge to SPDES limits. Use of perforated pipes or percolation pits for flows from oil containment is prohibited.

8.0 SECURITY

- A. The switchyard shall be totally enclosed by an 8' tall #9 AWG galvanized steel chain link fence with pipe rail at top and bottom and one foot topping of three strands of barbed wire. The fence, gates, and barbed wires shall be connected to the grounding system. A motorized sliding gate and a man gate shall be provided to facilitate traffic access to the switchyard. Sliding gate installation shall comply with ASTM F2200 and F1184. No gap between gate and fence post shall exceed 2". The yard shall be graded so that the bottom fence gap is maximum 1". The bottom gap at the motorized gate shall be maximum 4". The fence shall be constructed to accommodate a future fence-mounted intrusion detection system.
- B. The Developer shall provide the switchyard security system, including alarm system, PTZ (Pan Tilt Zoom) cameras, access point key card, and/or card readers, DVRs for CCTV, and appropriate lighting.
- C. The cameras shall be installed to capture the switchyard perimeter areas. As such, perimeter lighting for night time recording shall be even and low, approximately 1/5th of the surrounding area lighting.
- D. The cameras shall be controlled by the intrusion system.
- E. All security system component power including CCTV cameras, monitors, intrusion detection and alarm devices and panels shall be battery backed for 12 hours.
- F. The Developer shall take measures for animal deterrence such as physical barriers and other methods. A type of physical barrier would be a fence with small mesh fabric.
- G. Additional site specific security requirements may be applicable. Developer shall coordinate with NYPA.
- H. Developer shall provide a free standing sign near the road identifying the NYPA Switchyard (includes 911 signage); plus fence identification / emergency notification signage and HV safety signage.

9.0 FIRE PROTECTION, EQUIPMENT, AND PERSONNEL SAFETY

- A. Switchyard fire protection shall be designed in accordance with IEEE 979-1994 (R2004) Guide for Substation Fire Protection. Developer shall provide fire protection components including:
- Control and power cables used in the Control Building shall be constructed of a material that does not readily propagate fire and shall be qualified by the flame test parameters specified in the latest edition of IEEE Std. 383. Arrangement of control panels and electrical equipment shall be designed to meet the flame-retardant specifications as prescribed by latest edition of ANSI/IEEE Standard 420.
 - The Control Building shall have at least two exits located at opposite ends of the building. The arrangement of control panels and electrical equipment inside the Control Building shall be designed to allow personnel to exit the building from either side. The doors shall be adequately marked with illuminated exit signs and the doors shall open in the direction of egress. Doors shall be equipped with panic hardware that will override any exterior lock on the doors. Emergency lighting shall be installed in the Control Building. Emergency lighting shall also be installed on the exterior walls or the building at personnel exits to illuminate the area to allow persons to move away from the building. Emergency lighting and egress arrangement shall conform to the latest editions of ANSI/NFPA standards, NYS Fire Code, and NYSBC Chapter 11- Means of Egress.
 - Surge arresters shall be located as close as possible to the equipment they are protecting, yet minimize the possibility of damaging nearby equipment due to an exploding arrester. Surge arresters installed inside the Control Building shall be enclosed or located a safe distance away from passageways and combustibles to minimize the possibility of an equipment fire initiated from surges. Arresters shall be rigidly supported and properly grounded. Arrester arrangement shall conform to the guidance in the latest editions of IEEE. Arrester discharge vent direction shall be indicated on the drawings.
 - All floor and wall openings in the Control Building shall be sealed to maintain the fire rating of the floor or wall, as directed by NYSBC Chapter 7, "Fire Resistance Rated Construction". Conduits shall be sealed at ceiling, floor, and wall penetrations to prevent propagation of flame, smoke, and other gases/vapors from one area to another. Floor and wall openings shall be sealed in accord with a UL listed penetration detail to maintain the fire rating of the floor or wall.

- Portable fire extinguishers shall be located in the switchyard and in the Control Building including adjacent to normal entrance/exit doors. Only portable fire extinguishers having a nonconductive extinguishing agent, such as, dry chemical agent, or clean agent types shall be used on fires involving energized electrical equipment. Carbon dioxide fire extinguishers equipped with metal horns shall not be allowed. Carbon Dioxide type fire extinguishers shall not be used for battery room locations. Only portable dry chemical extinguishers shall be provided for the switchyard. The type, size, distribution, and installation of portable fire extinguishers shall be per the latest edition of ANSI/NFPA 10.
- All extinguishing agents shall be non-conductive.
- Specific fire safety measures for the Control Building are described in Section 5.
- SF₆ is a nonflammable gas that may generate by-products as a direct or indirect result of fire. Protection against SF₆ concentrations inside any enclosure housing equipment shall be considered in building/enclosure ventilation design. Precautions regarding the harmful effects of SF₆ gas and SF₆ gas by-products can be found in IEEE Std. C37.122.

The Developer should consider additional methods of fire protection:

- Physical separation of equipment
- Fire barriers
- If there isn't a municipal water main available, or if it is insufficient, then consider pressure maintenance pumps, water storage tanks or a private fire service
- Minimize spread of flammable oil by containment
- Fire Suppression Systems:
 - Portable Fire Extinguishers
 - Sprinkler Systems
 - Deluge System
 - Dry Chemical
 - Clean Agent

10.0 REGULATIONS, STANDARDS, AND CODES

Developers design and construction Work shall comply with regulations, standards, and codes including those listed below. The most recent edition of the listed documents in effect at the time of the construction shall apply. Any proposed exceptions shall be submitted. Any conflict between the standards or codes or regulations and the DCDC shall be submitted with explanation and proposed resolution to NYPA. In general, the more stringent requirement shall apply. Where an organization is listed include, without limitation, all codes, guides, and standards of that organization.

The design and construction of control building wiring shall meet the National Electrical Code (NEC; NFPA 70), NFPA 70E, NYSBC, and local Authority Having Jurisdiction (AHJ) requirements including lighting, receptacles, fire alarm detection, and protection, security, and HVAC.

NYPA Code Compliance shall issue Building Permits for Work on NYPA owned property. Developer shall follow NYPA procedures relating thereto. In addition, NYPA Code Compliance will act in an advisory capacity to the (AHJ) for the Construction Permits for the switchyard to be owned by NYPA. That AHJ shall not issue Temporary or Final Certificate(s) of Occupancy or Certificate(s) of Completion for the Work without prior written concurrence from NYPA. Developer shall implement NYPA Code Compliance department requirements as if NYPA were the AHJ.

Codes and Standards:

Aluminum Association
American Association of State Highway and Transportation Office
American Concrete Institute (ACI)
American Institute of Steel Construction Specification and Standards (AISC)
American National Standards Institute (ANSI)
American Society of Civil Engineers (ASCE)
American Society of Heating, Refrigerating, and Air-conditioning Engineers (ASHRAE)
American Society for Testing and Materials (ASTM)
American Welding Society Structural Welding Code (AWS)
Association of Edison Illuminating Companies (AEIC)

Concrete Reinforcing Steel Institute (CRSI)
Construction and Materials (NYSDOT Standards)

Illuminating Engineering Society Handbook

Institute of Electrical and Electronic Engineers (IEEE)
Insulated Cable Engineers Association (ICEA)

National Bureau of Standards (NBS)
National Electrical Code (NEC)
National Electrical Manufacturers Association (NEMA)
National Electrical Safety Code (NESC)
National Earthquake Hazards Reduction Program (NEHRP)
National Fire Protection Association (NFPA)
New York Code of Rules and Regulations (NYCRR)
New York State Building Code, including referenced standards.
New York State Department of Transportation
New York State Energy Conservation Construction Code
New York State Fire Code
New York State Fuel Gas Code
New York State Independent System Operator (NYISO)
New York State Mechanical Code
New York State Plumbing Code
New York State Reliability Council (NYSRC)
North American Electric Reliability Corporation (NERC)
Northeast Power Coordinating Council (NPCC)

Occupational Safety and Health Administration Standards (OSHA)

Sheet Metal and Air Conditioning Contractors National Association
(SMACNA)

Underwriters Laboratory (UL)
United States Code of Federal Regulations (CFR)
U.S. Army Corps of Engineers (USACE)
USDA Rural Utilities Service Bulletins

11.0 APPENDIX

APPENDIX A

STL – FDR PROJECT DRAWING INDEX

Prefix

100-3-Adirondack Substation
100-4-Saranac Substation
100-5-Cumberland Head
100-6-Plattsburgh Substation
100-8-Reynolds Substation
100-10-General Motors
100-13-Municipal & Coop.
100-14-Horton Sub. (MED)
100-D-Duley Substation
100-RY-Ryan Substation
110-VD-Hawkins Point Visitor Center
128-MTC-Marcy Training Center
174-MC-Marcy Substation
6487-MC-Marcy Substation
174-MS-Massena Substation
6489-MS-Massena Substation
176-W-Willis Substation
PA-5-RMPD, LSD, ID, MI & S.P.

PA-5-NUMERICAL INDEX

PA-5-1000 Architectural
PA-5-2000 Concrete
PA-5-3000 Structural
PA-5-4000 (See SEWCALM)
PA-5-5000 Mechanical
PA-5-6000 Iroquois Dam, Mass. Intake, Etc.
PA-5-7000 Mass. Intake, State Park, Etc.

TRANSMISSION LINE DWG. INDEX

100-MA1-Moses-Adir. MA-1 & 2
100-MA3-Moses-Adir. Third Ckt.
100-MW1-Moses-Willis-Platts. 1 WP1
100-PV20-Platts.-Vermont
100-PAF1-Platts.-Air Base
100-PSI-Platts.-Saranac
100-MR1-Moses Reynolds
100-RGM1-Reynolds-Gen. Motors 13.8KV
100-MRG-Moses-Reys.-GM

100-L33-P-Canadian Tie L34P
176-MWP-Moses-Willis-Platts.
174-MMS-Moses-Massena
174-MSUI-Massena Marcy 765KV
174-MS7040-Massena-Chateauguay 765KV

The Electrical Drawings are arranged in a uniform numbering sequence. The alphabetical numbering scheme describes the type of drawing.

S - Schematic
E - Elementary
W – Wiring
C – Conduit
A – Arrangement
L – Lighting
M – Miscellaneous
N – Numerical
T – Transmission

SCHEMATIC DRAWING INDEX

1S Index
2S Legend (see 3E also)
3S Relay Setting Sheets
4S Logic Diagram
5S Power System One Line
6S System Diagram
9S Metering & Relaying One Line
11S Grounding One Line
13S Protective Functions
15S D.C. Systems
17S 13.8KV One Line
18S 480V – One Line
25S Phasing
27S Communications (see 54E)
30S Computers
33S Monitors

ELEMENTARY DRAWING INDEX

1E Index
2E Internal Device Diagrams
3E Legend
5E Synchronizing
6E D.C. Systems
7E Generator and Sync. Cond. Control

- 8E Synchronous Condensers
- 9E Generator Instrumentation
- 10E Generator Excitation
- 11E Intake and Draft Tube
- 12E Relaying Generator
- 13E Transformer Relaying
- 14E Bus Relaying
- 15E Line Relaying Under Frequency Load Shedding
- 16E Breaker Failure and Backup Relaying
- 17E Breaker Control
- 18E Motor Operated Disconnect Control
- 19E Station Service Switchgear (13.8KV)
- 20E Disconnect Switches
- 21E Breaker Failure – Synchronous Condenser
- 22E A.C. Elementary
- 24E Annunciator
- 26E CO2 Systems and Fire Protection
- 28E Transformer Control
- 29E Reactor Bks. & Over-voltage
- 30E Oscilligraph
- 31E Watthour Metering
- 33E Drainage and Unwatering
- 34E Heating & Ventilating, Fire Dampers and Fans
- 35E Lighting
- 36E Miscellaneous
- 40E Station Service Switchgear (480V)
- 48E Load Frequency Control
- 50E Supervisory Control
- 52E Telemetry – Recorders, Transducers, RTD'S
- 53E Sequential Event Recorders
- 54E Communications
- 60E Centrimax
- 70E Cranes
- 80E Monitoring System

WIRING DRAWING INDEX

- 1W Index
- 6W Main Control Board
- 7W SERS Term. Cabs.
- 8W "R" Term. Cabinets
- 9W "L" Term. Cabinets
- 10W "C" Term. Cabinets
- 12W Station Service & Recorder Board
- 13W Data Acquisition Cabinets
- 14W "S" Term. Cabinets
- 16W "LR" Line Relaying Cabinets

18W “PDA” Potential Device Adjust
19W Pilot Wire Terminal Cabinets
20W “CC” Carrier Current Cabinets
21W CCT Carrier Current terminal Cabinets
22W Console – Control Room
23W Supervisory Console (Computer)
24W Generator Control Wiring
25W Generator Diff. Cabinets
26W Unit Boards
27W Synchronous Condenser
28W D.C. Station Batteries
29W Switchgear 13.8KV
30W Station Service Sw. Gr. (480V)
31W MCC – Motor Control Center
32W “M” Panels
36W Reactor Banks
38W Main Transformer Banks
40W Switchyard Wiring
41W Revenue Metering Panels
42W Communications System
44W Drum Gates
48W Drainage & Unwatering
50W Heating & Ventilating
60W Fire Protection
61W CO2 Wiring
65W Miscellaneous
66W Test Bench – Test Lab.
67W Test Lab. Control Panel
70W Gantry Cranes
80W Generator Condition Monitors

CONDUIT & GROUNDING INDEX

1C Index
2C Office Bay or Control House
3C Elevation 246.0 or Switchyard
4C Elevation 210.0
5C Ice Sluices
6C Elevation 194.5’ Units
7C Elevation 174.0’ Units
8C Elevation 159.0’ Units
9C Conduit Details
10C Conduit & Cable Schedule Index
11C Conduit & Cable Schedule
12C Tray & Cable Schedule

ARRANGEMENT INDEX

DESIGN CRITERIA FOR DEVELOPER CONNECTION
TO THE NEW YORK POWER AUTHORITY
TRANSMISSION SYSTEM

- 1A Index
- 2A Control House Arrangement
- 3A Miscellaneous Arrangement
- 5A Generator Main Leads (Isolated Phase Bus)
- 7A Main Transformer Arrangement
- 8A High Voltage Leads – Power Tunnel – Pipe Type Cable
- 10A Cable Trays
- 12A Crane Conductor System
- 22A Control areas

LIGHTING DRAWING INDEX

- 1L Lighting Index
- 2L Fixture Type Drawing or Control House & Tunnels
- 3L Lighting One Lines or Swyd. Miscellaneous Details
- 4L Lighting Plans
- 5L Lighting Panel Schedules
- 6L Lighting Panel Details
- 7L Lighting Wiring Diagrams
- 8L Lighting Miscellaneous Details

ALL ELECTRICAL EQUIPMENT OUTSIDE OF POWERHOUSE

- 1M Index
- 4M Switchyard Arrangement
- 6M Switchyard Plans & Sections
- 8M Switchyard Conduit & Grounding
- 10M Switchyard Lighting
- 12M Service Building
- 13M Switchyard Relay Building
- 14M Fan Houses
- 16M Maintenance Building
- 18M Maintenance Storage Building
- 19M Maintenance Storage Building No. 2
- 20M Boiler House & Water Tank
- 21M Office Annex
- 22M Guard House
- 24M Warehouse Building
- 26M Synchronous Condenser
- 30M Tower Take Off – Tower Line A-B-C-D
- 32M 13.8KV Distribution System
- 34M Sub – Distribution – Parkway Ltg. & Obstruction Ltg.
- 40M Coles Creek
- 50M Long Sault Dam
- 60M Construction Power
- 61M Cedar Rapids Transmission Line Relocation
- 70M Visitor Center

80M Eel Ladder

NUMERICAL INDEX

1N Index
4N Substation Topography
6N Grading Plan
8N Foundations
9N Foundation Repair
10N Swyd. Steel
12N Bldg. Arch. – Steel – Conc.
16N Heating & Vent.
18N Plumbing
19N Fire Alarm

TRANSMISSION INDEX

1T Index
3T Location Plan
4T Clearing ROW
5T ROW Map
7T Plan & Profile
8T Wood Str.
9T Steel Towers
10T Misc. Details
11T Counterpoise & Gndg.
13T Access
14T Stringing Tables
15T Obst. Ltg.
17T Phasing
19T Line Data